

# INSTALLATION AND OPERATION MANUAL

High Efficiency Air Handlers  
2-5 Tons Capacity | R454B

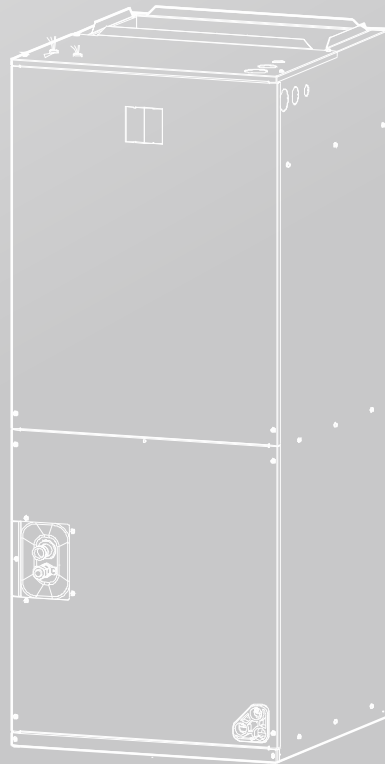

Please read this manual carefully and keep it for future reference.  
All the pictures in this manual are for illustrations purpose only.





RECOGNIZE THIS SYMBOL AS AN INDICATION OF IMPORTANT SAFETY INFORMATION

### **WARNING**

These instructions are intended as an aid to qualified licensed service personnel for proper installation, adjustment and operation of this unit. Read these instructions thoroughly before attempting installation or operation. Failure to follow these instructions may result in improper installation, adjustment, service, or maintenance, which could possibly lead to fire, electrical shock, property damage, personal injury, or even death.

## **Air Handler Features**

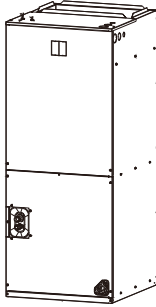

### **GREATER ECONOMY**

- High heat transfer efficiency and low static pressure drop due to the "A" shaped coil.
- Foil faced insulation to prevent energy loss through the cabinet.
- Factory-sealed cabinet certified to achieve an air leakage rate of 2% or less at 1.0 inch water column.
- Multi-Stage blower Speed Control to match different capacity demand better.
- Multi-speed Constant torque ECM motor.

### **GREATER CONVENIENCE**

- Multi-position installation: Upflow, Downflow, horizontal left and horizontal right.
- Horizontal and vertical condensate drain pans with standard, primary and secondary condensate fittings.
- Field-installed electric heater kits (5, 7.5, 10, 15, or 20 kW) available as an accessory.
- Multiple electrical entry locations.
- Dual front panel, volute and coil with slide track, TXV with threaded connection for easy maintenance.
- Integrated filter rack with tool-less door access.
- The connection of evaporator is copper, easy to braze.
- Replace piston to TXV easily.

### **GREATER RELIABILITY**

- All-aluminium heat exchanger to ensure long-life operation.
- Advanced internal welding process to reduce potential difference corrosion.
- AHRI listed and ETL listed.
- Polymer condensate drain pan with UVC inhibitor to improve anti-aging effect.
- Fully-insulated cabinet design.
- R454B refrigerant sensor is configured to ensure safe operation.
- R454B refrigerant sensor is factory-installed.

# CONTENTS

---

<b>1 SAFETY</b>	
• 1.1 Safety Signs .....	01
• 1.2 Safety Precautions .....	02
<b>2 ABOUT THE PRODUCT</b>	
• 2.1 Unit Dimensions .....	07
• 2.2 Parts Introduction .....	08
• 2.3 Attached Fittings .....	08
• 2.4 Refrigerant Sensor .....	09
<b>3 INSTALLATION</b>	
• 3.1 Installation Instructions .....	09
• 3.2 Vertical Upflow .....	12
• 3.3 Vertical Downflow .....	12
• 3.4 Horizontal .....	12
• 3.5 Installation in an Unconditioned Space .....	15
• 3.6 Refrigerant Charge and Room Area Limitations .....	15
<b>4 REFRIGERANT LINE</b> .....	18
<b>5 AIRFLOW PERFORMANCE (AIR HANDLERS ARE SUITABLE FOR MOBILE HOME APPLICATIONS)</b> .....	19
<b>6 DUCTWORK</b> .....	21
<b>7 ABOUT THE AIR FILTER</b>	
• 7.1 Air Filter (Not Factory-Installed) .....	22
• 7.2 Filter Installation Dimensions .....	22
<b>8 DRAIN PIPE INSTALLATION</b> .....	23
<b>9 ELECTRICAL WIRING</b>	
• 9.1 Control Wiring .....	25
• 9.2 Power Wiring .....	31
• 9.3 Alarm Wiring .....	32
• 9.4 Electric Heater Kit .....	33
<b>10 SETTING</b> .....	36
<b>11 SERVICE</b>	
• 11.1 Error Code and Troubleshooting .....	36
• 11.2 TXV Replacement Information .....	37
<b>12 DISPOSAL</b> .....	38

---

This document is customer property and is to remain with this unit.  
 These instructions do not cover all the different variations, nor do they provide nor does it provide for every possible contingency to be met in connection with installation.  
 All phases of this installation must comply with national state and local codes. If additional information is required, please contact your local distributor.

# 1 SAFETY

## 1.1 Safety Signs



This is the general warning sign. It is used to alert the user to potential hazards. All safety messages that follow this sign shall be obeyed to avoid possible harm.

### DANGER

Indicates a hazard with a high level of risk which, if not avoided, will result in death or serious injury.

### WARNING

Indicates a hazard with a medium level of risk which, if not avoided, could result in death or serious injury.





### CAUTION

Indicates a hazard with a low level of risk which, if not avoided, could result in minor or moderate injury.

### NOTE

A situation that may cause damage to the equipment or loss of property.

## Explanation of symbols displayed on the unit

	<b>DANGER</b>	This symbol shows that this appliance uses a mildly flammable refrigerant. If the refrigerant gets leaked and exposed to an external ignition source, there is a risk of fire.
	<b>WARNING</b>	This symbol shows that appliance shall be installed, operated and stored in a room with a floor area not less than the minimum room area.
	<b>CAUTION</b>	This symbol shows that the operation manual should be read carefully.
	<b>CAUTION</b>	This symbol shows that a service personnel should be handling this equipment with reference to the installation manual.
	<b>CAUTION</b>	This symbol shows that information is available such as in the operating manual or installation manual.

## 1.2 Safety Precautions

### **⚠ DANGER**

Disconnect all power to unit before installing or servicing. More than one disconnect switch may be required to de-energize the equipment. Hazardous voltage can cause severe personal injury or death.

### **⚠ WARNING**

If removal of the blower assembly is required, all disconnect switches supplying power to the equipment must be de-energized and locked (if not in sight of unit), so the field power wires can be safely removed from the blower assembly. Failure to do so may cause electrical shock, resulting in personal injury or death.

### **⚠ WARNING**

The unit must be permanently grounded. Failure to do so may result in electrical shock, causing personal injury or death.

### **⚠ WARNING**

Because of possible damage to equipment or personal injury, installation, service, and maintenance should be performed by a trained, qualified service personnel. Consumer service is recommended only for filter cleaning / replacement. Never operate the unit with the access panels removed.

### **⚠ WARNING**

These instructions are intended as an aid to qualified, licensed service personnel for proper installation, adjustment and operation of this unit. Read these instructions thoroughly before attempting installation or operation. Failure to follow these instructions may result in improper installation, adjustment, service or maintenance, possibly resulting in fire, electrical shock, property damage, personal injury or death.

### **⚠ CAUTION**

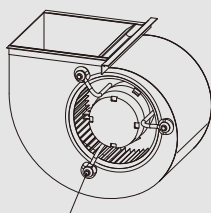

Make sure the blower motor support is tight (3-motor mount bolts), then check if wheel is secured to the motor shaft before operating the unit.

BLOWER MOTOR SHIPPING BOLT

Fig.1-1 Checking Motor Fix Status

### **⚠ WARNING**

**PROPOSITION 65:** This appliance contains fiberglass insulation. Respirable particles of fiberglass are known to the State of California to cause cancer.

All manufacturer products meet current federal OSHA Guidelines for safety. California Proposition 65 warnings are required for certain products, which are not covered by the OSHA standards.

California's Proposition 65 requires warnings for products sold in California that contain or produce any of over 600 listed chemicals known to the State of California to cause cancer or birth defects such as fiberglass insulation, lead in brass, and combustion products from natural vapor.

All "new equipment" shipped for sale in California will have labels stating that the product contains and/or produces Proposition 65 chemicals. Although we have not changed our processes, having the same label on all our products facilitates manufacturing and shipping. We cannot always know "when, or if" products will be sold in the California market.

You may receive inquiries from customers about chemicals found in, or produced by, some of our heating and air-conditioning equipment, or found in natural vapor used with some of our products. Listed below are those chemicals and substances commonly associated with similar equipment in our industry and other manufacturers.

- Glass Wool (Fiberglass) Insulation
- Carbon Monoxide (CO)
- Formaldehyde
- Benzene

More details are available on the following websites: OSHA (Occupational Safety and Health Administration), at [www.osha.gov](http://www.osha.gov) and the State of California's OEHHA (Office of Environmental Health Hazard Assessment), at [www.oehha.org](http://www.oehha.org). Consumer education is important since the chemicals and substances on the list are found in our daily lives. Most consumers are aware that products present safety and health risks, when improperly used, handled and maintained.

### **⚠ WARNING**

The first 6 inches of supply air plenum and ductwork must be constructed of sheet metal as required by NFPA 90B. The supply air plenum or duct must have a solid sheet metal bottom directly under the unit with no openings, registers or flexible air ducts located in it. If flexible supply air ducts are used, they may be located only in the vertical walls of rectangular plenum, a minimum of 6 inches from the solid bottom. Metal plenum of duct may be connected to the combustible floor base, if not, it must be connected to the unit supply duct exposed to the supply air opening from the downflow unit. Exposing combustible (non-metal) material to the supply opening of a downflow unit can cause a fire resulting in property damage, personal injury or death.

## WARNING

Only use this unit in a well-ventilated area and ensure unit's airflow inlet and outlet would not be impeded by obstructions. Do not use this unit in the following locations:

Locations with mineral oil.

Locations with saline atmospheres, such as seaside locations.

Locations with sulphurous atmospheres, such as near natural hot springs.

Where high voltage electricity is present, such as in certain industrial locations.

On vehicles or vessels, such as trucks or ferry boats.

Where exposure to oily or very humid air may occur, such as kitchens.

In proximity to sources of electromagnetic radiation, such as high-frequency transmitters or other high strength radiation devices.

## WARNING

Do not use means to accelerate the defrosting process or to clean, other than those recommended by the manufacturer.

The appliance shall be stored in a room that does not have continuously operating ignition sources (for example: open flames, an operating gas appliance or an operating electric heater).

Do not pierce or burn the unit.

Be aware that refrigerants may not contain an odour.

If refrigerant gas leaks during installation, ventilate the area immediately.

Comply with national gas regulations.

## WARNING

This appliance is not intended for use by people (including children) with reduced physical, sensory or mental capabilities, or people who lack experience and knowledge, unless they are supervised or have been given instructions concerning the use of the appliance by a person responsible for their safety.

Children should be supervised to ensure that they do not play with the appliance.

Any person who is involved with working on or opening a refrigerant circuit should hold a current valid certificate from an industry-accredited assessment authority, which authorizes their competence to handle refrigerants safely in accordance with an industry recognized assessment credential.

Servicing shall only be performed as recommended by the equipment manufacturer.

Maintenance and repair requiring the assistance of other skilled personnel shall be carried out under the supervision of a person competent in the use of flammable refrigerants.

Prior to beginning work on systems containing flammable refrigerants, safety checks are necessary to minimize the risk of ignition.

## WARNING

When repairing the refrigerating system, comply with the following precautions prior to conducting work on the system:

– shall be undertaken according to controlled procedures so as to minimize the risk of the presence of flammable gases or vapors while the work is being performed.

– All maintenance staff and others working in the local area shall be instructed on the nature of the work being carried out. Work in confined spaces shall be avoided.

– The area shall be checked with an appropriate refrigerant detector prior to and during work, to ensure the technician is aware of potentially toxic or flammable environment. Ensure that the leak detection equipment being used is suitable for use with all applicable refrigerants, i.e. non-sparking, adequately sealed or intrinsically safe.

– If any hot work is to be conducted on the refrigerating equipment or any associated parts, appropriate fire extinguishing equipment shall be available and easily accessible. Have a dry powder or CO2 fire extinguisher adjacent to the charging area.

– When carrying out work in relation to a refrigerating system that involves exposing any pipe work, no sources of ignition shall be used in such a manner that it may lead to the risk of fire or explosion. All possible ignition sources, including cigarette smoking, should be kept sufficiently far away from the site of installation, repair, or removal and disposal of the unit, during which refrigerant can possibly be released into the surrounding space. Prior to beginning work, the area around the equipment is to be surveyed to make sure that there are no flammable hazards or ignition risks. "No Smoking" signs shall be clearly displayed.

Ensure that the area is in the open or that it is adequately ventilated before opening the system or conducting any hot work. A degree of ventilation shall continue during the period that the work is carried out. The ventilation should safely disperse any released refrigerant and preferably expel it externally into the surroundings.

Where electrical components are being changed, they shall be fit according to their purpose and to the correct specification. At all times the manufacturer's maintenance and service guidelines shall be followed. If in doubt, consult the manufacturer's technical department for assistance. The following checks shall be applied to installations using flammable refrigerants:

– The actual refrigerant charge is in accordance with the room size within which the refrigerant containing parts are installed;

– The ventilation machinery and outlets are operating adequately and are not obstructed.

– If an indirect refrigerating circuit is being used, the secondary circuit shall be checked for the presence of refrigerant.

– Equipment marking must remain visible and legible. Markings and signs that are illegible shall be corrected.

Refrigerating pipe or components are installed in a position where they are unlikely to be exposed to any substances which may corrode refrigerant containing components, unless the components are constructed of materials that are inherently resistant to corrosion or are suitably protected against corrosion.

Repair and maintenance of electrical components shall include initial safety checks and component inspection procedures. If a fault exists that could compromise safety, then no electrical supply shall be connected to the circuit until the fault has been dealt with satisfactorily.

If the fault cannot be corrected immediately but it is necessary to continue operation, an adequate temporary solution shall be used. This shall be reported to the owner of the equipment so that all parties are advised. Initial safety checks shall include:

- That capacitors are discharged: this shall be done in a safe manner to avoid the possibility of sparking;
- That no live electrical components and wiring are exposed while charging, recovering or purging the system;
- That there is continuity of earthing.

## **WARNING**

Sealed electrical components shall be replaced.

Intrinsically safe components must be replaced.

Check that cabling will not be subject to wear, corrosion, excessive pressure, vibration, sharp edges or any other adverse environmental effects. The check shall also take into account the effects of aging or continual vibration from sources such as compressors or fans.

Under no circumstances shall potential sources of ignition be used while searching for or detecting refrigerant leaks. A halide torch (or any other detector using a naked flame) shall not be used.

Electronic leak detectors may be used to detect refrigerant leaks but, in the case of flammable refrigerants, the sensitivity may not be adequate, or may need re-calibration. (Detection equipment shall be calibrated in a refrigerant-free area.) Ensure that the detector is not a potential source of ignition and is suitable for the refrigerant used. Leak detection equipment shall be set at a percentage of the LFL of the refrigerant and shall be calibrated for the refrigerant employed, and the appropriate percentage of gas (25 % maximum) is confirmed.

If a leak is suspected, all naked flames shall be removed/extinguished.

If a leakage of refrigerant which requires brazing is found, all of the refrigerant shall be recovered from the system, or isolated (by means of shut off valves) in a part of the system remote from the leak.

Leak detection fluids are also suitable for use with most refrigerants but the use of detergents containing chlorine shall be avoided as the chlorine may react with the refrigerant and corrode the copper pipe-work.

NOTE: Examples of leak detection fluids are

- bubble method,
- fluorescent method agents.

When breaking into the refrigerant circuit to make repairs - or for any other purpose - conventional procedures shall be used. However, for flammable refrigerants it is important that best practice be followed, since flammability is a consideration. The following procedure shall be adhered to:

- safely remove refrigerant following local and national regulations.
- evacuate.
- purge the circuit with inert gas .
- evacuate.
- continuously flush or purge with inert gas when using flame to open circuit, and.
- open the circuit.

The refrigerant charge shall be recovered into the correct recovery cylinders if venting is not allowed by local and national codes. For appliances containing flammable refrigerants, the system shall be purged with oxygen-free nitrogen to render the appliance safe for flammable refrigerants. This process might need to be repeated several times. Compressed air or oxygen shall not be used for purging refrigerant systems.

For appliances containing flammable refrigerants, refrigerants purging shall be achieved by breaking the vacuum in the system with oxygen-free nitrogen and continuing to fill until the working pressure is achieved, then venting to atmosphere, and finally pulling down to a vacuum. This process shall be repeated until no refrigerant is within the system. When the final oxygen-free nitrogen charge is used, the system shall be vented down to atmospheric pressure to enable work to take place.

The outlet for the vacuum pump shall not be close to any potential ignition sources, and ventilation shall be available.

Ensure that contamination of different refrigerants does not occur when using charging equipment. Hoses or lines shall be as short as possible to minimize the amount of refrigerant they contain.

Cylinders shall be kept upright. Ensure that the refrigeration system is grounded prior to charging the system with refrigerant.

Label the system when charging is complete (if it is not already labeled).

Take extreme care not to overfill the refrigeration system.

Prior to recharging the system, it shall be pressure-tested with the appropriate purging gas. The system shall be leak-tested on completion of charging but prior to commissioning. A follow up leak test shall be carried out prior to leaving the site.

Before carrying out this procedure, it is essential that the technician is completely familiar with the equipment and all its detail. It is recommended that all refrigerants are recovered safely. Prior to the task being carried out, an oil and refrigerant sample shall be taken in case analysis is required prior to re-use of reclaimed refrigerant. It is essential that electrical power is available before the task is commenced.

- a) Become familiar with the equipment and its operation.
- b) Isolate system electrically.
- c) Before attempting the procedure ensure that:
  - mechanical handling equipment is available, if required, for handling refrigerant cylinders;
  - all personal protective equipment is available and used correctly;
  - the recovery process is supervised at all times by a competent person;
  - recovery equipment and cylinders conform to the appropriate standards.
- d) Pump down refrigerant system, if possible.
- e) If a vacuum is not possible, make a manifold so that refrigerant can be removed from various parts of the system.
- f) Make sure that the cylinder is situated on the scales before recovery takes place.
- g) Start the recovery machine and operate it in accordance with the manufacturer's instructions.
- h) Do not overfill cylinders. (No more than 80 % volume liquid charge).
- i) Do not exceed the maximum working pressure of the cylinder, even temporarily.
- j) When the cylinders have been filled correctly and the process has been completed, make sure that the cylinders and the equipment are removed from site promptly and all isolation valves on the equipment are closed off.
- k) Recovered refrigerant shall not be charged into another refrigeration system unless it has been cleaned and checked.

Equipment shall be labeled stating that it has been de-commissioned and emptied of refrigerant. The label shall be dated and signed. Ensure that there are labels on the equipment stating that the equipment contains flammable refrigerant.

When removing refrigerant from a system, either for servicing or decommissioning, it is recommended that all refrigerants are removed safely.

When transferring refrigerant into cylinders, ensure that only appropriate refrigerant recovery cylinders are employed. Ensure that the correct number of cylinders for holding the total system charge is available. All cylinders to be used are designated for the recovered refrigerant and labelled for that refrigerant (i.e. special cylinders for the recovery of refrigerant). Cylinders shall be complete with pressure-relief valve and associated shut-off valves in good working order. Empty recovery cylinders are evacuated and, if possible, cooled before recovery occurs.

The recovery equipment must be in good working order and come with a set of instructions for proper usage. Furthermore, the equipment should be suitable for safely recovering flammable refrigerants. If in doubt, the manufacturer should be consulted. In addition, a set of calibrated weighing scales shall be available and in good working order. Hoses shall be complete with leak-free disconnect couplings and in good condition.

The recovered refrigerant shall be processed according to local legislation in the correct recovery cylinder, and the relevant waste transfer note arranged. Do not mix refrigerants in recovery units and especially not in cylinders.

If compressors or compressor oils are to be removed, ensure that they have been evacuated to an acceptable level to be certain that flammable refrigerant does not remain within the lubricant. The compressor body shall not be heated by an open flame or other ignition sources to accelerate this process. When oil is drained from a system, it shall be carried out safely.

Do not use the air conditioner for other purposes. In order to avoid any quality deterioration, do not use the unit for the cooling of precision instruments, food, plants, animals or works of art. Before cleaning, be sure to stop the operation, turn the breaker off or unplug the supply cord. Otherwise, electric shock and injury may occur.

In order to avoid electric shock or fire, make sure that a ground leak detector is installed.

Never touch the air outlet or the horizontal blades while the swing flap is in operation. Your fingers may be caught or the unit may break down.

Never put any objects into the air inlet or outlet.

Objects touching the fan at high speed can be dangerous.

Never inspect or service the unit by yourself.

Ask a qualified service person to perform this task.

Do not dispose of this product as unsorted municipal waste. This waste should be collected separately for special treatment. Do not dispose of electrical appliances as unsorted municipal waste. Use separate collection facilities. Contact your local government for information regarding the connection systems available.

If electrical appliances are disposed of in landfills or dumps, hazardous substances can leak into the groundwater and get into the food chain, harming your health and well-being.

To prevent refrigerant leak, contact your dealer.

When the system is installed and operated in a small room, it is required to maintain the concentration of the refrigerant below the limit, in case a leak occurs. Otherwise, oxygen in the room may be affected, resulting in a serious accident.

The refrigerant in the air conditioner is safe and normally does not leak.

If the refrigerant leaks into the room and comes into contact with the fire of a burner, a heater or a cooker, a harmful gas could be released.

Turn off any combustible heating devices, ventilate the room, and contact the dealer from whom you purchased the unit.

Do not use the air conditioner until a service person confirms that the refrigerant leak is repaired.

Keep ventilation openings clear of obstruction.

### CAUTION

Be sure the air conditioner is grounded.

In order to avoid electric shock, make sure that the unit is grounded and that the ground wire is not connected to a gas or water pipe, lightning conductor or telephone ground wire.

Do not operate the air conditioner with wet hands. An electric shock may happen.

Do not touch the heat exchanger fins. These fins are sharp and could cut you.

To avoid oxygen deficiency, ventilate the room sufficiently if equipment with a burner is used together with the air conditioner.

Arrange the drain hose to ensure smooth drainage. Incomplete drainage may cause wetting of the building, furniture, etc.

Never touch the internal parts of the controller.

Do not remove the blower access panel. Some parts inside are dangerous to touch, and machine issues may occur.

Attention is drawn to the fact that additional transportation regulations may exist with respect to the equipment containing a flammable gas. The maximum number of pieces of equipment or the configuration of the equipment permitted to be transported together will be determined by the applicable transport regulations.

Signs for similar appliances used in a work area are generally addressed by local regulations and give the minimum requirements for the provision of safety and/or health signs for a work location.

All required signs are to be maintained and employers should ensure that employees receive suitable and sufficient instruction and

training on the meaning of appropriate safety signs and the actions that need to be taken in connection with these signs.

The effectiveness of signs should not be diminished by too many signs being placed together.

Any pictograms used should be as simple as possible and contain only essential details.

The storage of the appliance should be in accordance with the applicable regulations or instructions, whichever is more stringent.

Storage package protection should be constructed such a way that mechanical damage to the equipment inside the package will not cause a leak of the refrigerant charge.

The maximum number of pieces of equipment permitted to be stored together will be determined by local regulations.

Do not operate the air conditioner when using a room fumigation - type insecticide. Failure to observe this precaution could cause the chemicals to become deposited in the unit, which could endanger the health of those who are hypersensitive to chemicals. It may also cause the refrigerant sensor to alarm.

Do not place appliances which produce open flames in places exposed to the air flow from the unit or under the indoor unit. It may cause incomplete combustion or deformation of the unit due to the heat.

Do not install the air conditioner in a location where flammable gas may leak out. If the gas leaks out and stays around the air conditioner, a fire may break out.

Any additional equipment installed in our unit may not cause negative influence on normal operation, such as UV lights, humidifier and etc.

The appliance uses R454B refrigerant.



## 2 ABOUT THE PRODUCT

### 2.1 Unit Dimensions

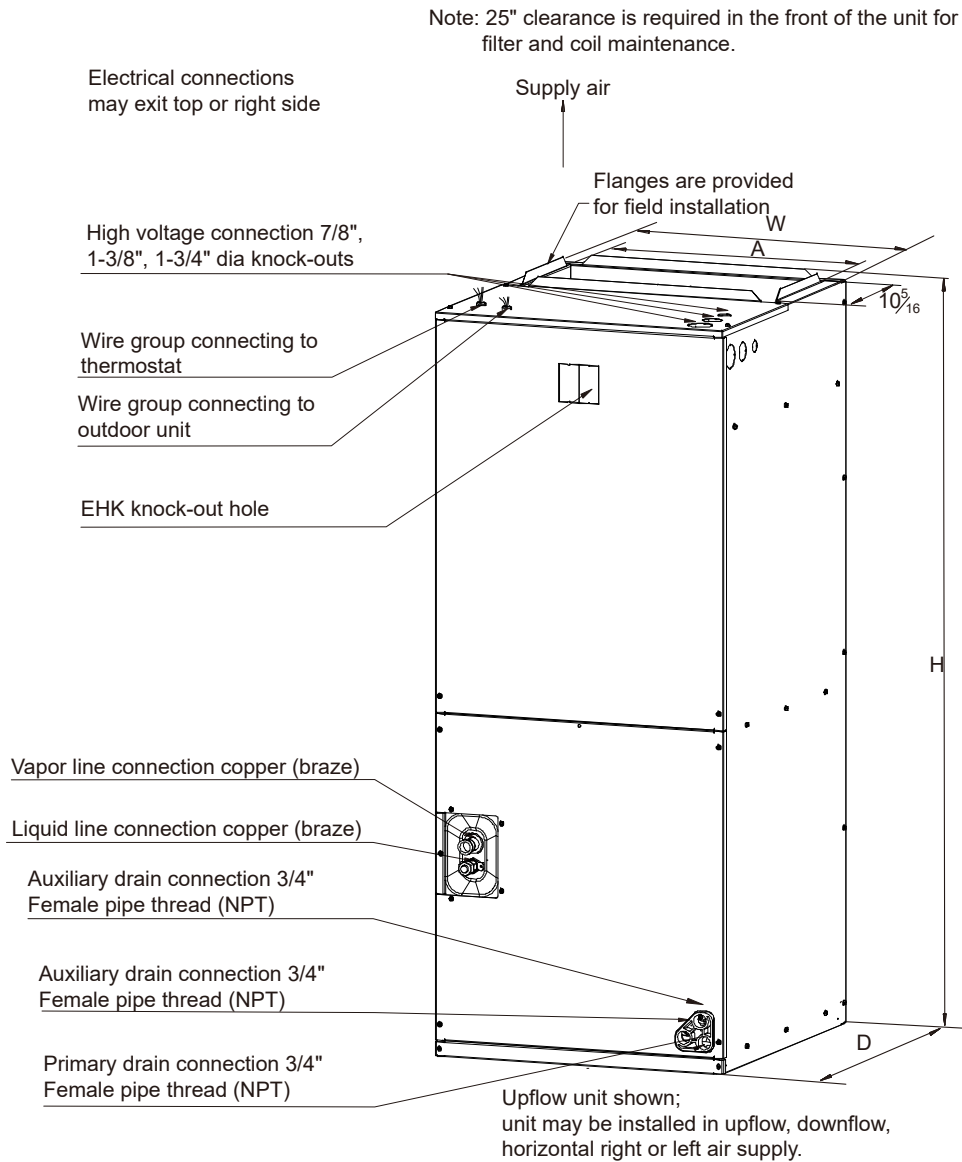

Fig.2-1 Dimensions

#### Dimensional Data

Model Size	Unit Height "H" in [mm]	Unit Width "W" in [mm]	Unit Length "D" in [mm]	Supply Duct "A"	Unit Weight (lb [kg])
24	41-3/8" [1050]	18-1/8" [460]	20-1/2" [520]	16" [406]	99 [45]
36	46-1/2" [1180]	19-5/8" [500]	21-5/8" [550]	18" [456]	121 [55]
48	54-1/2" [1385]	22" [560]	24" [610]	19-1/2" [496]	150 [68]
60	54-1/2" [1385]	22" [560]	24" [610]	19-1/2" [496]	150 [68]
61	54-1/2" [1385]	22" [560]	24" [610]	19-1/2" [496]	159 [72]

Table 2-1

## 2.2 Parts Introduction

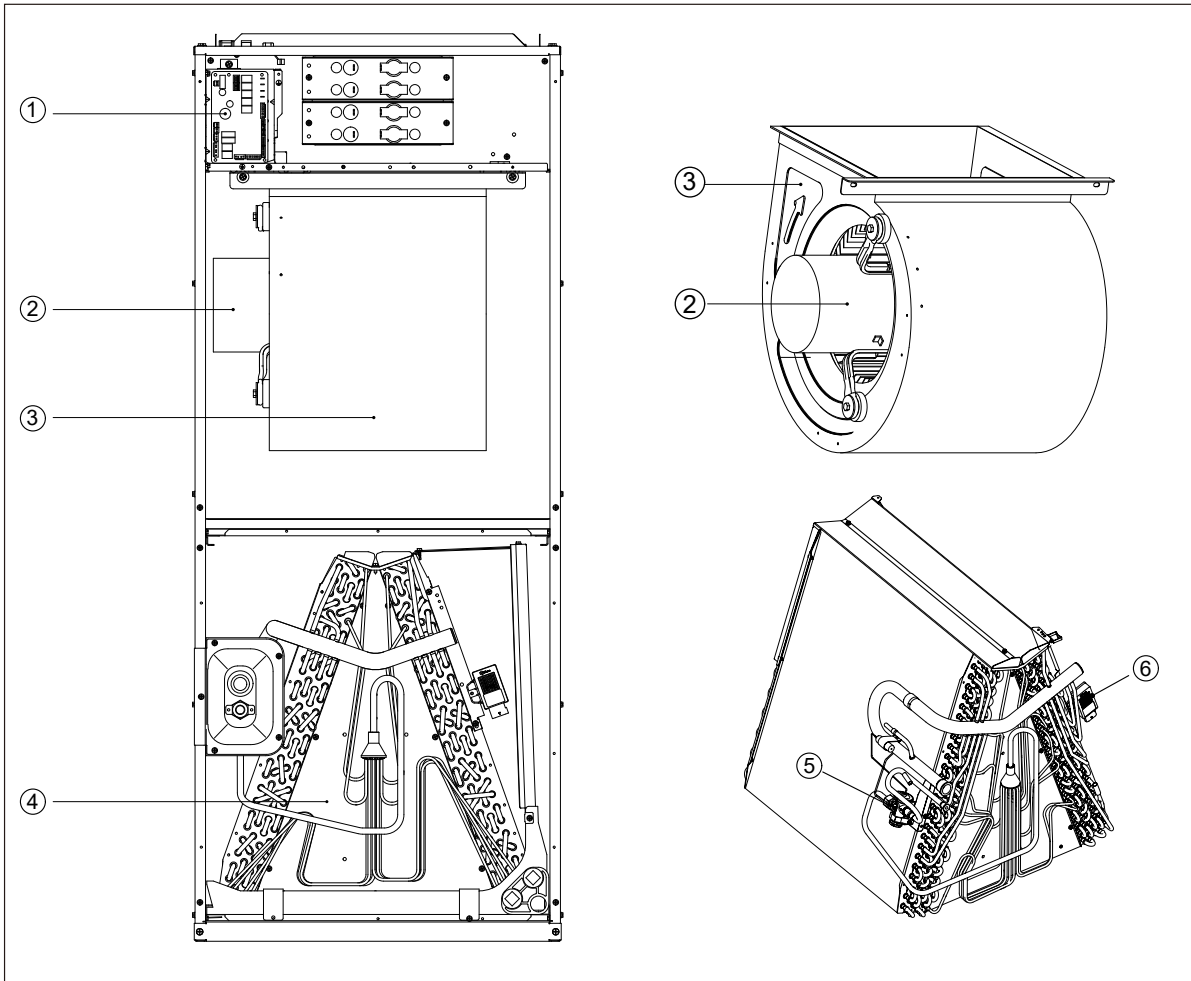



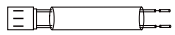



Fig.2-2

Number	①	②	③	④	⑤	⑥
Parts	Control Board	DC Motor	Blower	AL-Evaporator	R454B-TXV	R454B Refrigerant Sensor

Table 2-2

## 2.3 Attached Fittings

	Name	Appearance	Quantity	Name	Appearance	Quantity
Installation Fittings	Indoor unit operation and installation manual		1	Sealing ring		3
	Accessory package		1	Alarm output wires		1
	Seal plug		2			

Note: The above list is for most models, different models of the attached fittings list may be slightly different.

Check if any accessory in the above figure is missing. All the accessories must be kept properly. All the fittings should be factory fittings.

## 2.4 Refrigerant Sensor

R454B refrigerant leakage sensor is configured for the indoor unit. To meet different installation scenarios, the refrigerant sensor has two installation positions. The factory set of the refrigerant sensor is applied to the vertical upflow and horizontal right. The refrigerant sensor needs to be relocated for vertical downflow and horizontal left. Before installing the indoor unit, check whether the refrigerant sensor is correctly installed according to Section 3.

### CAUTION

The refrigerant leakage sensor can only use the factory model or the specified model indicated in the corresponding manual.

The R454B refrigerant leakage sensor must be used to activate the refrigerant shut-off device, the alarm device, incorporated circulation airflow or other emergency controls, which shall give an electrical signal at a predetermined alarm set point in response to leaked refrigerant.

The location of leakage sensors shall be chosen in relation to the different installation scenarios. Please refer to the indoor unit installation manual for specific requirements.

The installation of the refrigerant leakage sensor shall allow access for checking, repair or replacement by an authorized person.

The refrigerant leakage sensor shall be installed so its function can be verified easily.

The refrigerant leakage sensor shall be protected to prevent tampering or unauthorized resetting of the pre-set value.

To be effective, the refrigerant leakage sensor must be electrically powered at all times after installation, other than when servicing.

If the refrigerant leakage sensor detects a refrigerant leak, the fan will be turned on to the maximum, and the compressor will stop running. You should immediately leave the leak area and notify a professional for handling.

The service life of the refrigerant sensor is 15 years, and it should be replaced after the service life.

To ensure the detection accuracy of the refrigerant sensor, it is recommended to blow dust off the surface of the refrigerant sensor after it is used for a long time.

### WARNING

LEAK DETECTION SYSTEM installed on indoor unit. Unit must be powered on except for during servicing period.

### NOTE

The R454B refrigerant leakage sensor is configured for the indoor unit. The fan operation can be initiated by the R454B refrigerant sensor, ensuring that it meets the required circulation airflow requirements. The allowed maximum refrigerant charge ( $M_{max}$ ) and the required minimum room area ( $A_{min}$ ) can be determined according to Table 3-2 and Table 3-3.

## 3 INSTALLATION

### 3.1 Installation Instructions

The unit can be positioned for bottom return air in the upflow position, left and right return in the horizontal position, top return in downflow position.

This air handler provides the flexibility for installation in any upflow, downflow, or horizontal application. The direct drive motors provide a selection of air volume to match any application. 5-Speed motors provide selections of air flow to meet desired applications.

The power wiring and control wiring are set on the top and right of the unit. Accessible screw terminals are provided for the control wiring, making the installation process easy and minimizing installation costs. See Fig.3-1.

Do not install unit in an area where flammable materials are present due to the risk of an explosion resulting in serious injury or death.

If the supporting structural members are not strong enough to handle the unit's weight, the unit could fall out of place and cause serious injury.

If a return-air duct is not installed, carefully select the location and method of product installation so that air flow into the product will not be blocked.

The unit should be installed in a level position to ensure proper condensation drainage. Up to an additional  $\frac{1}{4}$ " rise over the width or depth of the unit is allowed to create additional sloping towards the drain. Unit must be positioned between level and  $\frac{1}{4}$ " rise, sloping toward the drain connections.

Install the indoor and outdoor unit power supply wiring and connecting wires at least 3.5 ft. away from televisions or radios in order to prevent image interference or noise.

To ensure the proper installation, select a solid and level site.

Ensure that there is enough space for installation and maintenance.

See Fig.3-1 and Fig.3-2.

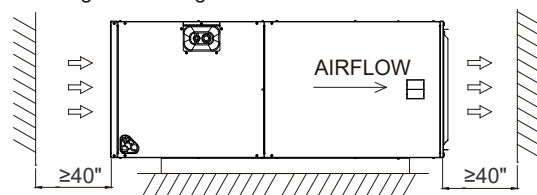

Fig.3-1 Clearances in the horizontal position

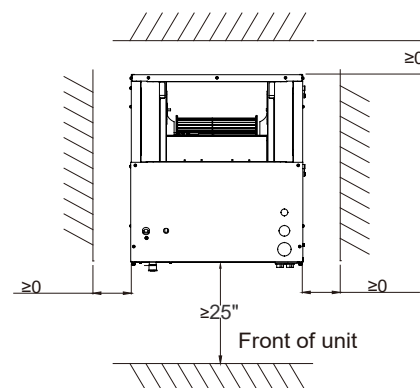

Fig.3-2 Clearances in the vertical position

When the unit is installed in a hot and humid place, If the humidity inside the installation space might exceed 86 °F and RH 80 %, it is recommended to insulate the cabinet exterior.

Use glass wool or polyethylene foam as insulation so that the thickness is more than 2 inches and fits inside the installation space opening.

Respectively, condensation may form on the surface of the insulation.

Be sure to use insulation that is designed for use with HVAC Systems.

Condensation may form on the product during cooling operation. It is also recommended to use second drain pan and secure the unit firmly to prevent it from falling. See Fig.3-3 , Fig.3-4, Fig.3-5, Fig.3-6.

**⚠ WARNING**

These instructions are exclusively intended for qualified contractors and authorized installers.

Work on the refrigerant circuit with flammable refrigerant in safety group A2L may only be carried out by authorized contractors. These heating contractors must be trained in accordance with UL 60335-2-40, Section HH. The certificate of competence from an industry accredited body is required.

Work on electrical equipment may only be carried out by a qualified electrician.

Before initial commissioning, all safety – related points must be checked by the particular certified heating contractors. The system must be commissioned by the system installer or a qualified person authorized by the installer.

For installation of the indoor unit, refer to the corresponding installation and operation manual. If an indoor unit is installed in an unventilated area, the area shall be so constructed that should any refrigerant leak, it will not stagnate so as to create a fire or explosion hazard.

The appliance shall be stored so as to prevent mechanical damage from occurring.

Do not stack combustible materials on the surface of the indoor unit.

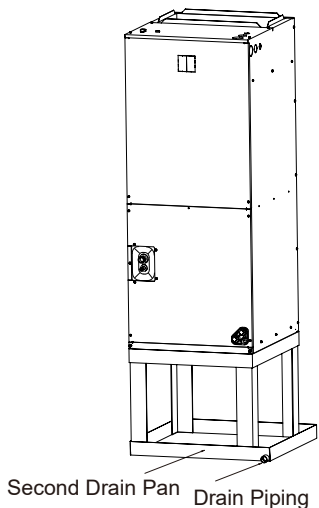

Fig.3-3 Installed vertically upflow

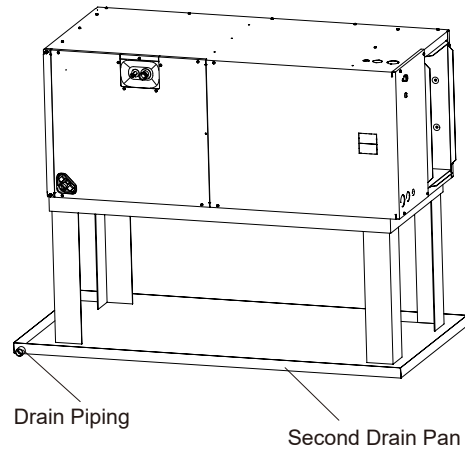

Fig.3-4 Installed horizontally right

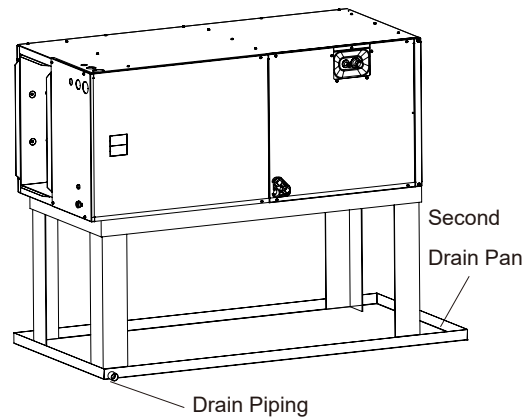

Fig.3-5 Installed horizontally left

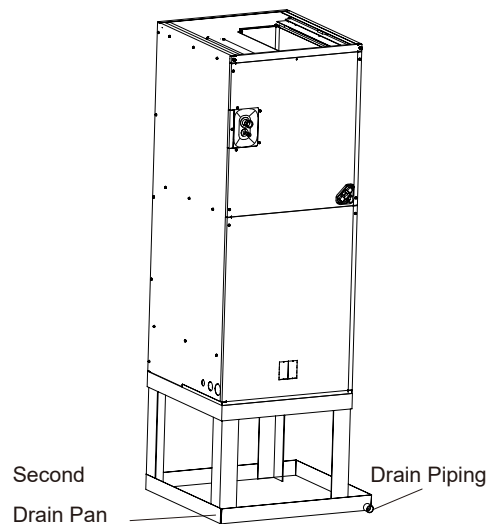

Fig.3-6 Installed vertically downflow

**⚠ WARNING**

Ensure the apparatus is mounted securely.

**NOTE**

If installed vertically downflow in a hot and humid place that might exceed 86 °F and RH 80 %, such as in the basement, the extra drain pan, sponge and sealant shall be installed as shown in Fig.3-7. Sealant must meet the fire rating requirements of 5VA. The extra drain pan is an optional part that is not factory-installed. You can consult dealers or manufacturers to buy it. No matter how the unit is installed, as long as the knock-out hole is used, the knock-out hole needs to use sealant.

**STEP1**

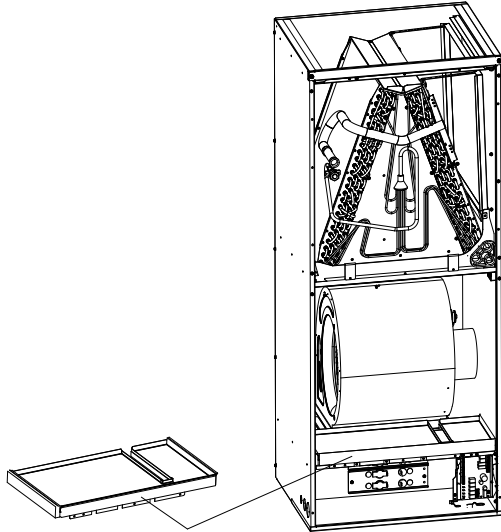

Extra Drain Pan

Note: Extra drain pan is optional part, isn't factory-installed.

Note: High voltage connection 7/8", 1-3/8", 1-3/4" dia knock-outs, sealant must be applied here.

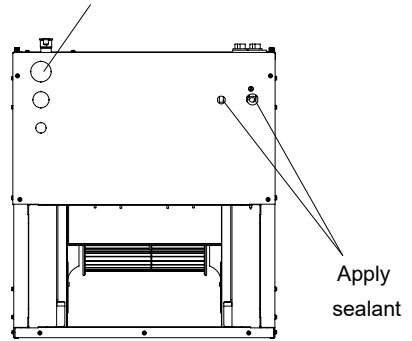

**STEP2**

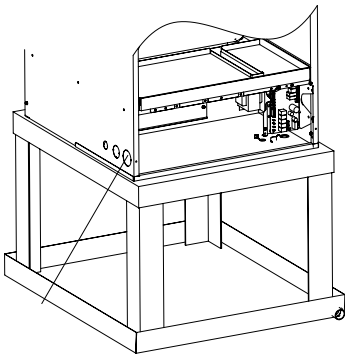

Note: High voltage connection 7/8", 1-3/8", 1-3/4" dia knock-outs, sealant must be applied here.

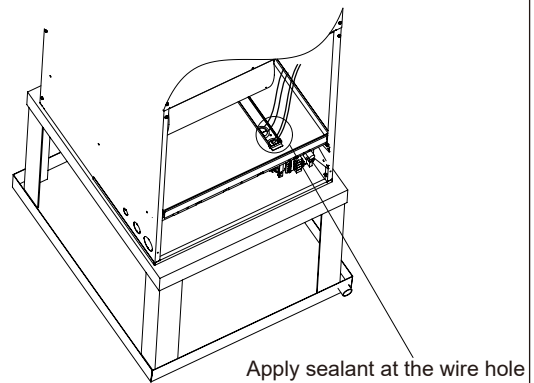

Fig.3-7 Extra pan and sealant installed

### 3.2 Vertical Upflow

Vertical Upflow configuration is the factory set on all models. See Fig.3-8.

If return air is to be ducted, install duct flush with floor. Use fireproof resilient gasket 1/8 to 1/4 in. thick between the ducts, unit and floor. Set unit on floor over opening.

#### IMPORTANT NOTE

Torque applied to drain connections should not exceed 15 ft.lb. For vertical upflow and horizontal right installations, dimensions for refrigerant and drain pipes may be found in Fig.3-8.

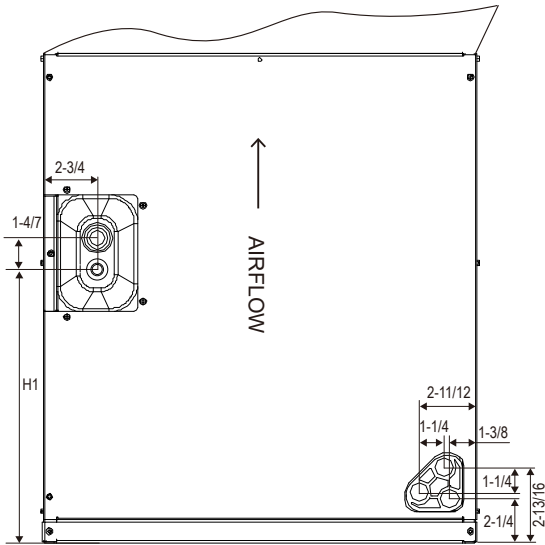

Fig.3-8 Dimensions for air handler (Coil Section)

Model	"H1" in [mm]
24	8-7/8 [226.0]
36	13-1/5 [335.5]
48/60/61	13-7/8 [352.8]

### 3.3 Vertical Downflow

#### Conversion to Vertical Downflow:

A vertical upflow unit may be converted to vertical downflow. See Fig.3-8 and Fig.3-9.

1. Remove the coil access panel
2. Remove the refrigerant leak detection sensor and indoor coil.
3. Reinstall indoor coil 180 degrees from original position.
4. Reinstall the refrigerant sensor at the location shown in Fig.3-10.

#### CAUTION

The refrigerant leak detection sensor needs to be relocated in this application. Please follow the steps in the next page.

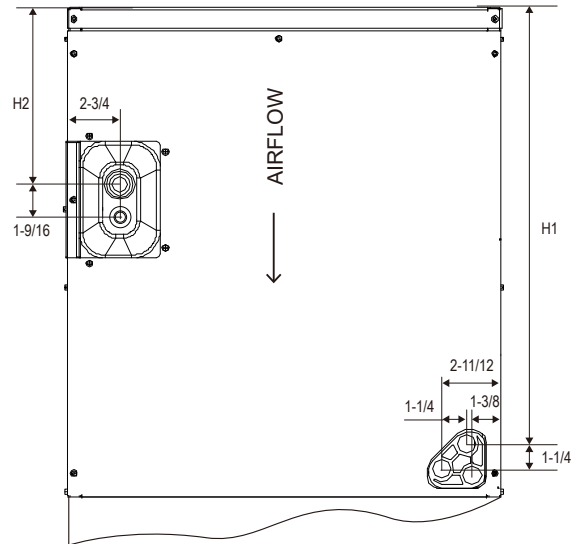

Fig.3-9 Dimensions for air handler (Coil Section)  
Dimensional Data

Model	"H1" in [mm]	"H2" in [mm]
24	14-5/8 [372.0]	8-3/8 [213.0]
36	17-2/5 [441.5]	6-2/5 [162.5]
48/60/61	22-1/6 [563.5]	10-1/2 [267.2]

### 3.4 Horizontal

Horizontal right is the default factory configuration for all models.

#### CAUTION

When the air handler is in horizontal left position, the refrigerant detection sensor needs to be relocated. Please follow the steps on the following page to do this.

A vertical upflow unit may be converted to horizontal left by removing the indoor coil assembly and the refrigerant leak detection sensor. Reinstall the indoor coil and the refrigerant sensor for left hand air supply. See Fig.3-10.

- Rotate the unit 90° into the horizontal left position, with the coil compartment on the right and the blower compartment on the left.
- Remove the coil access panel.
- Remove the refrigerant leak detection sensor and indoor coil.
- Reinstall the indoor coil 180° from original position. Ensure the retaining channel is fully engaged with the coil rail. See Fig.3-10 and 3-11.
- An additional field supplied drain pan kit is recommended when the unit is configured for the horizontal position over a finished ceiling and/or living space.

## Steps for Changing Cabinet Orientation to Vertical Downflow or Horizontal Left Orientation

1. Remove the screws and front panel and disconnect the refrigerant sensor from the control board.
2. Pull out the coil with refrigerant sensor (Figure 3-10, Step 2).
3. Unscrew and remove the refrigerant sensor and housing from the evaporator coil. Then place and screw in the refrigerant sensor housing at the sensor position shown in the Figure 3-10, Step 3).
4. Replace the coil in the correct orientation and secure in place. Plug the refrigerant sensor wire back to the controlboard(Figure 3-10, Step 3).
5. Reinstall the front panel and secure with screws.

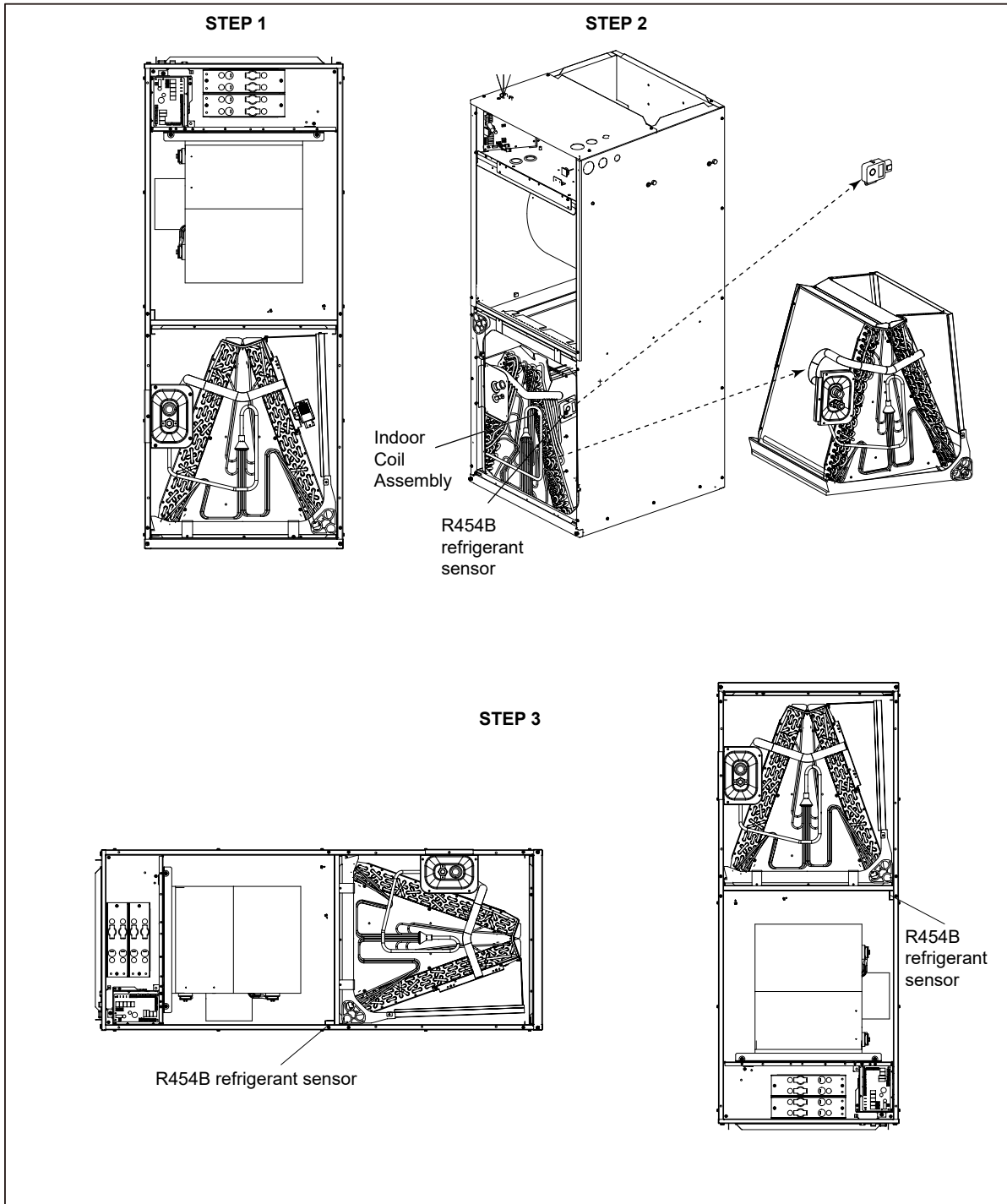

Fig.3-10 Vertical Downflow & Horizontal Left Applications Conversion

When installing the evaporator, ensure the retaining channel is fully engaged with the coil rail.

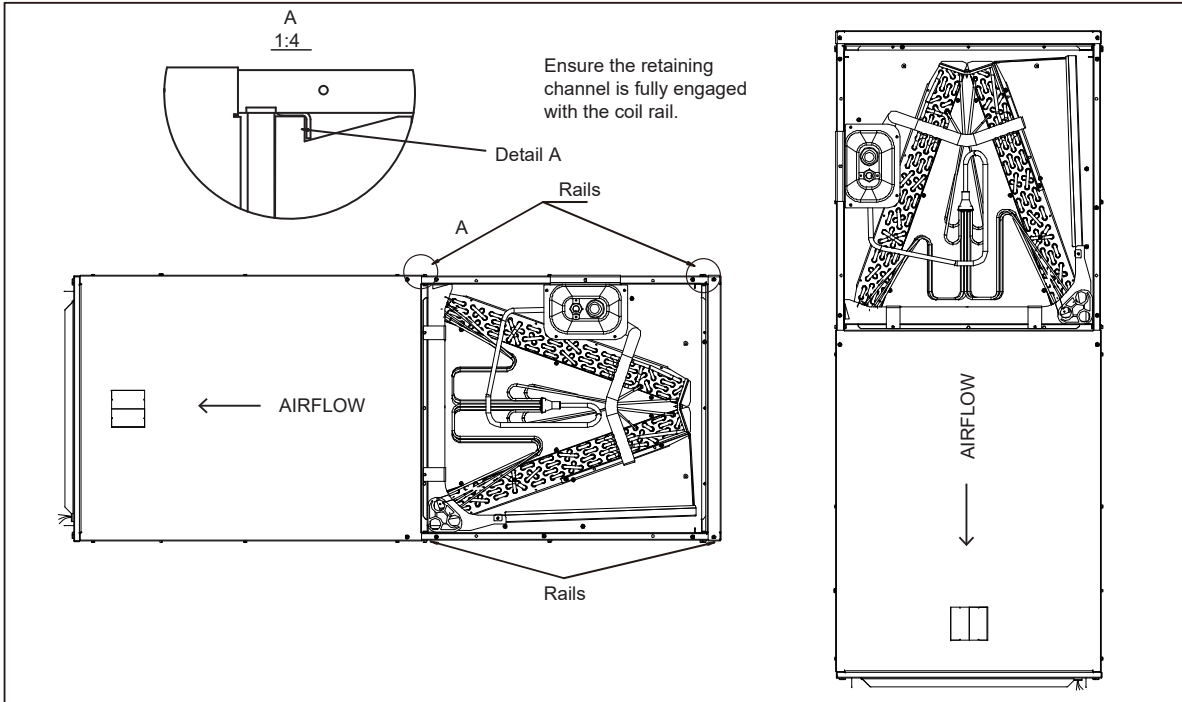

Fig.3-11 Vertical Downflow & Horizontal Left Applications

**NOTE**

Horizontal units must be configured for right hand air supply or left hand air supply. Horizontal drain pan must be located under indoor coil. Failure to use the drain pan can result in property damage.

**Conversion in Horizontal Direction:**

Horizontal right-hand supply can be changed to horizontal left-hand supply by removing the indoor coil and reinstalling 180° from original.

Indoor coil and drain pan set-up, as shown in the Fig.3-12. (Take 48K as example)

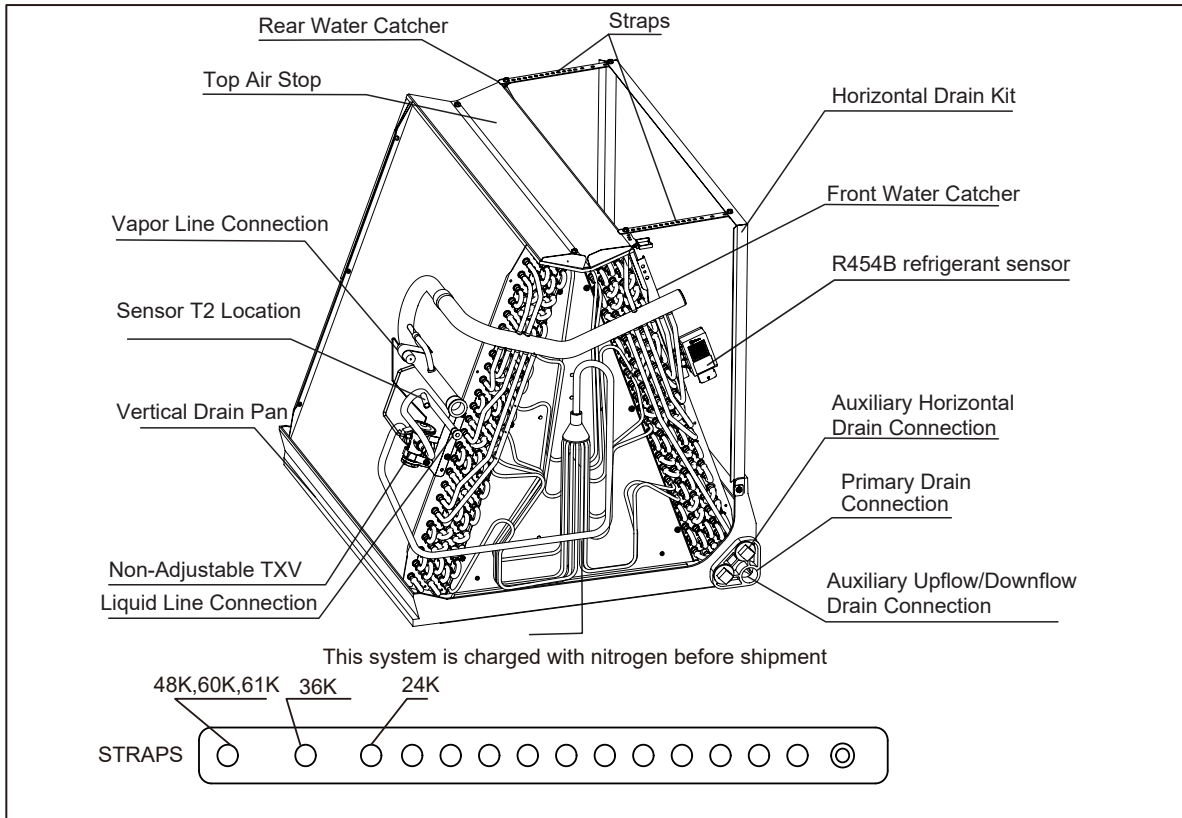

Fig.3-12 Indoor Coil and Drain Pan Set-up

### 3.5 Installation in an Unconditioned Space

#### NOTE

There are two pairs of coil rails in the air handler for upflow and downflow application. If the air handler is installed in an unconditioned space, the two unused coil rails should be removed to minimize air handler surface sweating. The coil rails can be easily removed by unscrewing the 6 mounting screws from both sides of the cabinet.

### 3.6 Refrigerant Charge and Room Area Limitations

In UL/CSA 60335-2-40, R454B refrigerant is classified as class A2L, which is mildly flammable. Therefore, R454B refrigerant would limit the area of the rooms being served.

Similarly, the total amount of refrigerant in the system shall be less than or equal to the allowable maximum refrigerant charge. The allowable maximum refrigerant charge depends on the area of the rooms being served by the system.

#### NOTE

The nouns in this section are explained as follows:

Mc: The actual refrigerant charge in the system.  
A: the actual room area where the appliance is installed.

Amin: The required minimum room area.

Mmax: The allowable maximum refrigerant charge in a room.

Qmin : The minimum circulation airflow.

Anvmin: The minimum opening area for connected rooms.

TAmin: The required minimum total area of the conditioned space (For appliances serving two or more rooms with an air duct system).

TA: The total area of the conditioned space connected by air ducts (For appliances serving two or more rooms with an air duct system).

#### 3.6.1 The room area calculation requirements

#### CAUTION

The space considered shall be any space which contains refrigerant-containing parts or into which refrigerant could be released.

The room area (A) of the smallest, enclosed, occupied space shall be used in the determination of the refrigerant quantity limits.

For determination of room area (A) when used to calculate the refrigerant charge limit, the following shall apply.

The room area (A) shall be defined as the room area enclosed by the projection to the base of the walls, partitions and doors of the space in which the appliance is installed.

Spaces connected by only drop ceilings, ductwork, or similar connections shall not be considered a single space.

Units mounted higher than 70-55/64 inches and spaces divided by partition walls that are no higher than 62-63/64 inches shall be considered a single space.

Rooms on the same floor and connected by an open passageway between the spaces can be considered a single room when determining compliance to Amin, if the passageway complies with all of the following.

- 1) It is a permanent opening.
- 2) It extends to the floor.
- 3) It is intended for people to walk through.

The area of the connected rooms, on the same floor, connected by permanent opening in the walls and/or doors between occupied spaces, including gaps between the wall and the floor, can be considered a single room when determining compliance to Amin, provided all of the following conditions are met as Fig. 3-13.

##### 1) Low level opening

① The opening shall not be less than Anvmin in Table 3-1.

② The area of any openings above 11-13/16 inches from the floor shall not be considered in determining compliance with Anvmin.

③ At least 50 % of the opening area of Anvmin shall be below 7-7/8 inches from the floor.

④ The bottom of the opening is not more than 3-15/16 inches from the floor.

⑤ The opening is a permanent opening that cannot be closed.

⑥ For openings extending to the floor the height shall not be less than 25/32 inches above the surface of the floor covering.

##### 2) High level opening

① The opening shall not be less than 50 % of Anvmin in Table 3-1.

② The opening is a permanent opening that cannot be closed.

③ The opening shall be at least 59 inches above the floor.

④ The height of the opening is not less than 25/32 inches.

##### 3) Room size requirement

① The room into which refrigerant can leak, plus the connected adjacent room(s) shall have a total area not less than Amin. Amin is shown in Table 3-3.

② The room area in which the unit is installed shall be not less than 20 % Amin. Amin is shown in Table 3-3.

#### NOTE

The requirement for the second opening can be met by drop ceilings, ventilation ducts, or similar arrangements that provide an airflow path between the connected rooms.

The minimum opening for natural ventilation ( $An_{vmin}$ ) in connected rooms is related to the room area ( $A$ ), the actual refrigerant charge of refrigerant in the system ( $Mc$ ), and the allowable MAXIMUM REFRIGERANT CHARGE in the system ( $M_{max}$ ),  $An_{vmin}$  can be determined according to Table 3-1.

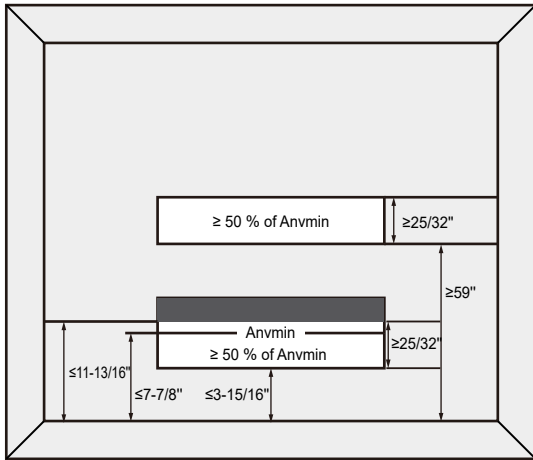

Fig.3-13 Opening Conditions for Connected Rooms

The minimum opening area for connected rooms

A (ft <sup>2</sup> )	Mc (□lb□oz)		Mmax (□lb□oz)		Anvmin (ft <sup>2</sup> )
	lb	oz	lb	oz	
100	17	3	6	10	1.3
110	17	3	7	5	1.2
120	17	3	8	0	1.1
130	17	3	8	10	1.0
140	17	3	9	5	1.0
150	17	3	10	0	0.9
160	17	3	10	10	0.8
170	17	3	11	5	0.7
180	17	3	12	0	0.6
190	17	3	12	10	0.5
200	17	3	13	5	0.5
210	17	3	14	0	0.4
220	17	3	14	10	0.3
230	17	3	15	5	0.2
240	17	3	16	0	0.1
250	17	3	16	10	0.1
260	17	3	17	5	0.0

Table 3-1

Note: Take the  $Mc = 17$  lb 3 oz as an example.

For appliances serving two or more rooms with an air duct system, The room area calculation shall be determined based on the total area of the conditioned space (TA) connected by ducts taking into consideration that the circulating airflow distributed to all the rooms by the appliance integral indoor fan will mix and dilute the leaking refrigerant before entering any room.

### 3.6.2. The allowed maximum refrigerant charge and required minimum room area

If the fan incorporated in the appliance is continuously operated or operation is initiated by a REFRIGERANT DETECTION SYSTEM with a sufficient CIRCULATION AIRFLOW rate, the allowable maximum refrigerant charge ( $M_{max}$ ) and the required minimum room area ( $A_{min}/TA_{min}$ ) is shown in Table 3-2 and Table 3-3.

The allowable maximum refrigerant charge

A/TA (ft <sup>2</sup> )	Mmax (□lb□oz)		A/TA (ft <sup>2</sup> )	Mmax (□lb□oz)	
	lb	oz		lb	oz
40	2	10	160	10	10
50	3	5	170	11	5
60	4	0	180	12	0
70	4	10	190	12	10
80	5	5	200	13	5
90	6	0	210	14	0
100	6	10	220	14	10
110	7	5	230	15	5
120	8	0	240	16	0
130	8	10	250	16	10
140	9	5	260	17	5
150	10	0			

Table 3-2

The required minimum room area

Mc (□lb□oz)		Amin/TAmin (ft <sup>2</sup> )	Mc (□lb□oz)		Amin/TAmin (ft <sup>2</sup> )
lb	oz		lb	oz	
4	6	66.1	11	0	165.3
4	13	72.7	11	7	171.9
5	4	79.3	11	14	178.5
5	11	86.0	12	5	185.1
6	2	92.6	12	12	191.7
6	9	99.2	13	3	198.4
7	0	105.8	13	10	205.0
7	7	112.4	14	1	211.6
7	15	119.0	14	8	218.2
8	6	125.6	14	15	224.8
8	13	132.2	15	6	231.4
9	4	138.8	15	14	238.0
9	11	145.5	16	5	244.6
10	2	152.1	16	12	251.2
10	9	158.7	17	3	257.9

Table 3-3

The minimum circulation airflow

Mc (lb/oz)		Qmin (CFM)	Mc (lb/oz)		Qmin (CFM)
lb	oz		lb	oz	
4	6	119	11	0	298
4	13	131	11	7	310
5	4	143	11	14	322
5	11	155	12	5	334
6	2	167	12	12	346
6	9	179	13	3	358
7	0	191	13	10	370
7	7	203	14	1	382
7	15	215	14	8	394
8	6	227	14	15	406
8	13	239	15	6	418
9	4	251	15	14	430
9	11	263	16	5	442
10	2	275	16	12	454
10	9	287	17	3	466

Table 3-4

**CAUTION**

The allowable maximum refrigerant charge of the Table 3-2 or the required minimum room area of the Table 3-3 is available only if the following conditions are met:

Minimum velocity of 3.28 ft/s, which is calculated as the indoor unit airflow divided by the nominal face area of the outlet. the grill area shall not be deducted.

Minimum airflow rate must meet the corresponding values in Table 3-4, which is related to the actual refrigerant charge of the system (Mc).

R454B refrigerant leakage sensor is configured.

**NOTE**

The maximum refrigerant limit described above applies to unventilated areas. If adding additional measures, such as areas with mechanical ventilation or natural ventilation, the maximum refrigerant charge can be increased or the minimum room area can be reduced.

The R454B refrigerant leakage sensor is configured for the indoor unit and meets the incorporated circulation airflow requirements. The maximum refrigerant charge or minimum room area can be determined according to Table 3-2 or Table 3-3.

**CAUTION**

If the actual room area, air outlet height, and refrigerant charge amount are not reflected in the above table, more severe cases need to be considered according to the data in the table3-1, 3-2, 3-3, 3-4.

● Installation scheme flow chart

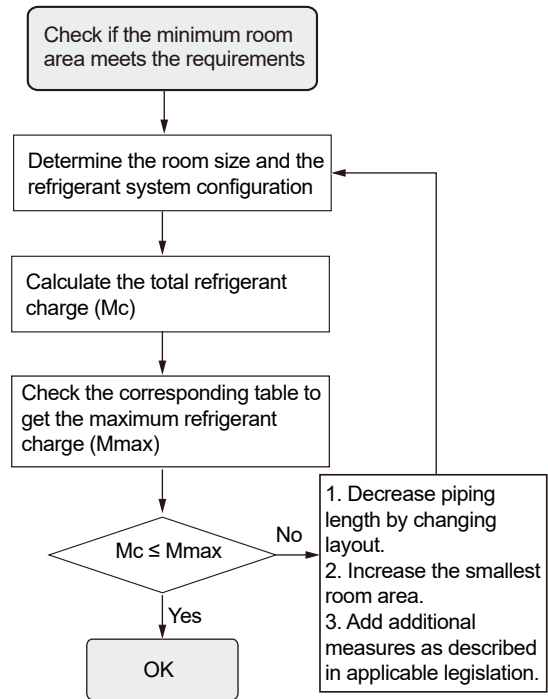

Fig.3-14

## 4 REFRIGERANT LINE

The suction pipe and liquid pipe of the indoor unit need to be protected and cannot be grabbed when moving the indoor unit.

Keep the coil connections sealed until refrigerant connections are made. See the Installation Instructions for the outdoor unit for details on line sizing, tubing installation, and charging information.

Coil is shipped with Nitrogen. Evacuate the system before charging with refrigerant.

Install refrigerant tubing so that it does not block service access to the front of the unit.

Nitrogen should flow through the refrigerant lines while brazing.

Use a brazing shield to protect the cabinet's paint and a wet rag to protect the rubber grommet and input pipe's TXV seal ring from being damaged by torch flames.

After the refrigerant connections are made, seal the gap around the connections with pressure sensitive gasket.

The pipe-work, including piping material, pipe routing, and installation, must be protected from physical damage during operation and service. Additionally, it should comply with national and local codes and standards, such as ASHRAE 15, ASHRAE 15.2, IAPMO Uniform Mechanical Code, ICC International Mechanical Code, or CSA B52. Prior to being covered or enclosed, all field joints must be accessible for inspection.

All joints made in the installation between parts of the refrigerating system, with at least one part charged, shall be made in accordance with the following:

— A brazed, welded, or mechanical connection shall be made before opening the valves to permit refrigerant to flow between the refrigerating system parts. A vacuum valve shall be provided to evacuate the interconnecting pipe or any uncharged refrigerating system part.

— Mechanical connectors used indoors shall comply with ISO 14903. When mechanical connectors are reused indoors, sealing parts shall be renewed. When flared joints are reused indoors, the flare part shall be refabricated.

— Refrigerant tubing shall be protected or enclosed to avoid damage.

— Flexible refrigerant connectors (such as connecting lines between the indoor and outdoor unit) that may be displaced during normal operation shall be protected against mechanical damage.

Compliance is checked according to the installation instructions and a trial installation, if necessary.

Field-made refrigerant joints indoors shall be tightness tested. The test method shall have a sensitivity of 5 grams per year of refrigerant or better under a pressure of at least 0.25 times the maximum allowable pressure. No leak shall be detected.

After completion of field piping for split systems, the field pipework shall be pressure tested with an inert gas and then vacuum tested prior to refrigerant charging, according to the following requirements.

The minimum test pressure for the low side of the system shall be the low side design pressure and the minimum test pressure for the high side of the system shall be the high side design pressure, unless the high side of the system, cannot be isolated from the low side of the system in which case the entire system shall be pressure tested to the low side design pressure.

Field-made refrigerant joints indoors shall be tightness tested. The test method shall have a sensitivity of 5 grams per year of refrigerant or better under a pressure of at least 0.25 times the maximum allowable pressure. No leak shall be detected.

— mechanical joints in compliance with ISO 14903 or UL 207 (U.S. only).

— welded or brazed joints.

— joints in enclosures that vent to the unit or to the outside.

Compliance is checked by inspection and tests.

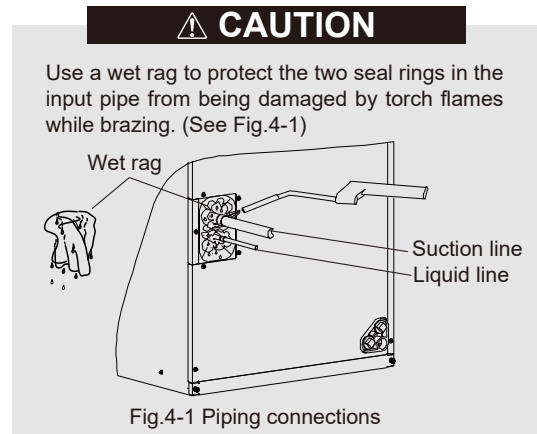

Fig.4-1 Piping connections

After the brazing work is finished, make sure to check if there is refrigerant leakage. After checking for vapor leaks, be sure to insulate the pipe connections referring to Fig.4-2.

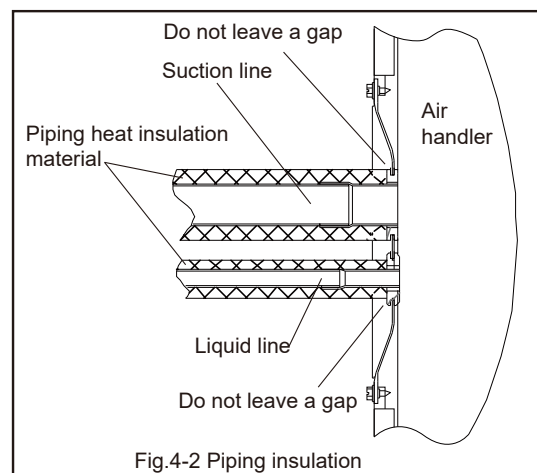
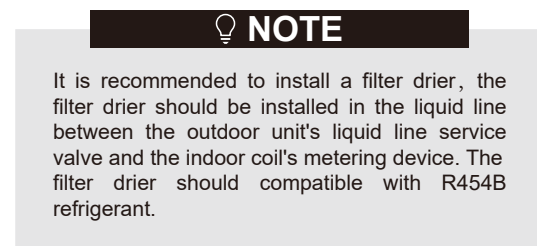

Fig.4-2 Piping insulation



## 5. AIRFLOW PERFORMANCE (AMERISTAR AIR HANDLERS ARE SUITABLE FOR MOBILE HOME APPLICATIONS)

Airflow performance data is based on cooling performance with a coil and no filter in place. Select performance table for appropriate unit size.

External static applied to unit allows operation within the minimum and maximum limits shown in table below for both cooling and electric heat operation.

Airflow Performance Data

Model Number	Outdoor Unit Size (Tons)	Motor Speed		CFM Wet Coil without filter and Electric Heat								
				External Static Pressure (in w.c)								
				0	0.1	0.2	0.3	0.4	0.5	0.6	0.7	0.8
24	1.5	1	Current / A	0.63	0.67	0.7	0.74	0.77	0.81	0.84	0.88	0.9
			Power / W	72	78	82	87	92	97	102	107	112
			CFM	676	608	550	492	422	369	311	274	233
		2	Current / A	0.81	0.85	0.89	0.93	0.97	1	1.04	1.09	1.12
			Power / W	98	103	109	114	120	124	130	136	140
			CFM	770	717	666	615	552	512	457	406	364
		3	Current / A	1.14	1.18	1.22	1.26	1.31	1.36	1.41	1.45	1.49
			Power / W	143	148	154	159	166	172	178	183	189
			CFM	903	856	808	767	722	665	618	577	535
		4	Current / A	1.42	1.46	1.51	1.55	1.6	1.65	1.69	1.75	1.8
			Power / W	179	185	191	197	203	210	215	223	229
			CFM	987	945	900	861	821	766	737	677	636
		5	Current / A	1.66	1.71	1.76	1.81	1.86	1.91	1.95	2	2.06
			Power / W	211	217	224	230	237	244	249	255	264
			CFM	1055.6	1012.3	970.6	930.3	883.4	844.9	811.8	774.8	715.3
24	2	1	Current / A	0.63	0.67	0.7	0.74	0.77	0.81	0.84	0.88	0.9
			Power / W	72	78	82	87	92	97	102	107	112
			CFM	676	608	550	492	422	369	311	274	233
		2	Current / A	0.81	0.85	0.89	0.93	0.97	1	1.04	1.09	1.12
			Power / W	98	103	109	114	120	124	130	136	140
			CFM	770	717	666	615	552	512	457	406	364
		3	Current / A	1.14	1.18	1.22	1.26	1.31	1.36	1.41	1.45	1.49
			Power / W	143	148	154	159	166	172	178	183	189
			CFM	903	856	808	767	722	665	618	577	535
		4	Current / A	1.42	1.46	1.51	1.55	1.6	1.65	1.69	1.75	1.8
			Power / W	179	185	191	197	203	210	215	223	229
			CFM	987	945	900	861	821	766	737	677	636
		5	Current / A	1.66	1.71	1.76	1.81	1.86	1.91	1.95	2	2.06
			Power / W	211	217	224	230	237	244	249	255	264
			CFM	1056	1012	971	930	883	845	812	775	715
36	2.5	1	Current / A	1.05	1.09	1.14	1.19	1.27	1.33	1.4	/	/
			Power / W	113	119	126	133	144	151	158	/	/
			CFM	1013	946	891	823	709	634	566	/	/
		2	Current / A	1.45	1.5	1.56	1.61	1.66	1.76	1.83	1.89	1.95
			Power / W	166	174	181	188	195	208	218	225	234
			CFM	1180	1123	1072	1023	969	865	794	733	674
		3	Current / A	1.87	1.93	1.99	2.05	2.1	2.15	2.25	2.35	2.42
			Power / W	224	232	240	248	255	262	276	288	299
			CFM	1335	1283	1231	1189	1146	1093	1009	923	864
		4	Current / A	2.42	2.49	2.55	2.61	2.67	2.73	2.79	2.87	2.99
			Power / W	299	308	317	325	334	342	350	361	378
			CFM	1484	1437	1386	1347	1309	1271	1231	1176	1075
		5	Current / A	2.92	2.99	3.07	3.14	3.19	3.25	3.35	3.49	3.50
			Power / W	369	378	388	397	404	411	424	441	443
			CFM	1560	1520	1480	1442	1403	1378	1323	1248	1179
36	3	1	Current / A	1.05	1.09	1.14	1.19	1.27	1.33	1.4	/	/
			Power / W	113	119	126	133	144	151	158	/	/
			CFM	1013	946	891	823	709	634	566	/	/
		2	Current / A	1.45	1.5	1.56	1.61	1.66	1.76	1.83	1.89	1.95
			Power / W	166	174	181	188	195	208	218	225	234
			CFM	1180	1123	1072	1023	969	865	794	733	674
		3	Current / A	1.87	1.93	1.99	2.05	2.1	2.15	2.25	2.35	2.42
			Power / W	224	232	240	248	255	262	276	288	299
			CFM	1335	1283	1231	1189	1146	1093	1009	923	864
		4	Current / A	2.42	2.49	2.55	2.61	2.67	2.73	2.79	2.87	2.99
			Power / W	299	308	317	325	334	342	350	361	378
			CFM	1484	1437	1386	1347	1309	1271	1231	1176	1075

Model Number	Outdoor Unit Size (Tons)	Motor Speed		CFM Wet Coil without filter and Electric Heat										
				External Static Pressure (in w.c)										
				0	0.1	0.2	0.3	0.4	0.5	0.6	0.7	0.8		
36	3	5	Current / A	2.92	2.99	3.07	3.14	3.19	3.25	3.35	3.49	3.50		
			Power / W	369	378	388	397	404	411	424	441	443		
			CFM	1560	1520	1480	1442	1403	1378	1323	1248	1179		
48/60	3.5	1	Current / A	1.56	1.63	1.71	1.77	1.83	1.90	2.02	2.10	/		
			Power / W	198	209	220	226	231	241	260	270	/		
			CFM	1420	1374	1320	1269	1218	1158	1037	957	/		
		2	Current / A	2.10	2.20	2.28	2.34	2.39	2.46	2.54	2.63	2.78		
			Power / W	267	279	289	297	303	312	322	334	353		
			CFM	1613	1558	1516	1469	1425	1375	1327	1274	1147		
		3	Current / A	2.78	2.87	2.96	3.03	310.00	3.17	3.25	3.32	3.41		
			Power / W	369	383	398	408	419	428	439	450	465		
			CFM	1796	1757	1707	1663	1622	1580	1539	1467	1451		
		4	Current / A	3.46	3.55	3.67	3.75	3.84	3.92	3.99	4.07	4.15		
			Power / W	472	482	502	513	523	537	548	560	573		
			CFM	1978	1944	1887	1850	1805	1765	1722	1678	1632		
		5	Current / A	4.17	4.26	4.38	4.47	4.57	4.67	4.74	4.83	4.92		
			Power / W	575	590	605	621	634	651	662	675	690		
			CFM	2123	2092	2051	2011	1971	1922	1889	1852	1818		
		48/60	4	1	Current / A	1.56	1.63	1.71	1.77	1.83	1.90	2.02	2.10	/
					Power / W	198	209	220	226	231	241	260	270	/
					CFM	1420	1374	1320	1269	1218	1158	1037	957	/
2	Current / A			2.10	2.20	2.28	2.34	2.39	2.46	2.54	2.63	2.78		
	Power / W			281	294	305	313	319	329	339	351	371		
	CFM			1613	1558	1516	1469	1425	1375	1327	1274	1147		
3	Current / A			2.78	2.87	2.96	3.03	310.00	3.17	3.25	3.32	3.41		
	Power / W			369	383	398	408	419	428	439	450	465		
	CFM			1796	1757	1707	1663	1622	1580	1539	1467	1451		
4	Current / A			3.46	3.55	3.67	3.75	3.84	3.92	3.99	4.07	4.15		
	Power / W			472	482	502	513	523	537	548	560	573		
	CFM			1978	1944	1887	1850	1805	1765	1722	1678	1632		
5	Current / A			4.17	4.26	4.38	4.47	4.57	4.67	4.74	4.83	4.92		
	Power / W			575	590	605	621	634	651	662	675	690		
	CFM			2123	2092	2051	2011	1971	1922	1889	1852	1818		
48/60	5			1	Current / A	1.56	1.63	1.71	1.77	1.83	1.90	2.02	2.10	/
					Power / W	198	209	220	226	231	241	260	270	/
					CFM	1420	1374	1320	1269	1218	1158	1037	957	/
		2	Current / A	2.10	2.20	2.28	2.34	2.39	2.46	2.54	2.63	2.78		
			Power / W	267	279	289	297	303	312	322	334	353		
			CFM	1613	1558	1516	1469	1425	1375	1327	1274	1147		
		3	Current / A	2.78	2.87	2.96	3.03	310.00	3.17	3.25	3.32	3.41		
			Power / W	369	383	398	408	419	428	439	450	465		
			CFM	1796	1757	1707	1663	1622	1580	1539	1467	1451		
		4	Current / A	3.46	3.55	3.67	3.75	3.84	3.92	3.99	4.07	4.15		
			Power / W	472	482	502	513	523	537	548	560	573		
			CFM	1978	1944	1887	1850	1805	1765	1722	1678	1632		
		5	Current / A	4.17	4.26	4.38	4.47	4.57	4.67	4.74	4.83	4.92		
			Power / W	575	590	605	621	634	651	662	675	690		
			CFM	2123	2092	2051	2011	1971	1922	1889	1852	1818		
		61	6	1	Current / A	1.58	1.64	1.72	1.78	1.85	1.96	2.03	2.10	2.15
					Power / W	199	208	220	229	237	250	260	270	280
					CFM	1395	1352	1296	1243	1190	1094	1010	940	888
2	Current / A			2.11	2.21	2.28	2.36	2.41	2.48	2.56	2.70	2.77		
	Power / W			273	289	298	310	318	329	340	360	370		
	CFM			1587	1537	1492	1435	1401	1348	1293	1180	1116		
3	Current / A			2.78	2.84	2.92	3.04	3.10	3.18	3.26	3.32	3.43		
	Power / W			372	380	391	406	415	428	439	450	465		
	CFM			1782	1769	1691	1643	1610	1564	1523	1484	1424		
4	Current / A			3.47	3.55	3.64	3.73	3.93	3.90	4.00	4.07	3.94		
	Power / W			470	480	492	510	521	530	550	560	571		
	CFM			1962	1931	1885	1844	1798	1764	1715	1683	1635		
5	Current / A			4.26	4.30	4.38	4.45	4.52	4.64	4.74	4.83	4.92		
	Power / W			589	590	605	617	628	642	660	670	688		
	CFM			2123	2075	2034	1996	1962	1919	1882	1844	1805		

--- Shaded boxes represent airflow outside the required 300-450 cfm/ton, which are not recommended.

NOTES: Airflow based upon cooling performance at 230V with no electric heat and no filter. Airflow at 208V is approximately the same as 230V because the multi-tap ECM motor is a constant torque motor. The torque doesn't drop off at the speeds in which the motor operates.

The air distribution system has the greatest effect on airflow. The duct system is totally controlled by the contractor. For this reason, the contractor should use only industry-recognized procedures.

Heat pump systems require a specified airflow for electric heat operating. Each ton of cooling requires between 350 and 450 cubic feet of air per minute (CFM), or 400 CFM nominally.

Duct design and construction should be carefully done. System performance can be lowered dramatically through bad planning or workmanship.

Air supply diffusers must be selected and located carefully. They must be sized and positioned to deliver treated air along the perimeter of the space. If they are too small for their intended airflow, they become noisy. If they are not located properly, they cause drafts. Return air grilles must be properly sized to carry air back to the blower. If they are too small, they also cause noise.

The installers should balance the air distribution system to ensure proper quiet airflow to all rooms in the home. This ensures a comfortable living space.

An air velocity meter or airflow hood can be used to balance and verify branch and system airflow (CFM).

## 6 DUCTWORK

Field ductwork must comply with the National Fire Protection Association NFPA 90A, NFPA 90B and any applicable local ordinance.

### DANGER

Do not, under any circumstances, connect return ductwork to any other heat producing device such as fireplace insert, stove, etc.

Unauthorized use of such devices may result in fire, carbon monoxide poisoning, explosion, personal injury or property damage.

Sheet metal ductwork in unconditioned spaces must be insulated and covered with a vapor barrier. Fibrous ductwork may be used if constructed and installed in accordance with SMACNA Construction Standard on Fibrous Glass Ducts. Ductwork must comply with National Fire Protection Association as tested by UL Standard 181 for Class I Air Ducts. Check local codes for requirements on ductwork and insulation.

- The duct system must be designed to operate within the range of external static pressure specified for the unit. It is crucial to ensure that the system airflow is adequate. Take into account the total resistance caused by supply and return ductwork, grills, special filters, accessories, etc. Please refer to the airflow performance tables provided in this manual.
- Design the duct system in accordance with "ACCA" Manual "D" Design for Residential Winter and Summer Air Conditioning and Equipment Selection. Latest editions are available from: "ACCA" Air Conditioning Contractors of America, 1513 16th Street, N.W., Washington, D.C. 20036. If duct system incorporates flexible air duct, be sure pressure drop information (straight length plus all turns) shown in "ACCA" Manual "D" is accounted for in the system.
- Supply plenum is attached to the 3/4" duct flanges supplied with the unit. Attach flanges around the blower outlet.

**IMPORTANT:** If an elbow is included in the plenum close to the unit, it can not be smaller than the dimensions of the supply duct flange on the unit.

**IMPORTANT:** If the front flange on the return duct is connected to the blower casing, it should not be screwed into the area where the power wiring is located. Drills or sharp screw points can damage insulation on wires located inside unit.

- Secure the supply and return ductwork to the unit flanges, using proper fasteners for the type of duct used and tape the duct-to-unit joint as required to prevent air leaks.

### WARNING

If appliances connected via an air duct system to one or more rooms are installed in a room with an area less than shown in section 3.6 Table3-3, that room shall be without continuously operating open flames (e.g. an operating gas appliance) or other potential ignition sources (for e.g. an operating electric heater, hot surfaces). A flame-producing device may be installed in the same space if the device is provided with an effective flame arrest.

For appliances connected via an air duct system to one or more rooms, auxiliary devices which may be a potential ignition source shall not be installed in the duct work. Examples of such potential ignition sources are hot surfaces with a temperature exceeding 700 °C and electric switching devices.

For appliances connected via an air duct system to one or more rooms, only auxiliary devices approved by the appliance manufacturer or declared suitable with the refrigerant shall be installed in connecting ductwork.

## 7 ABOUT THE AIR FILTER

### 7.1 Air Filter (Not Factory-Installed)

External filter or other means of filtration is required. Units should be sized for a maximum of 300 feet/min air velocity or what is recommended for the type of filter installed.

Filter application and placement are critical to airflow, which may affect the heating and cooling system performance. Reduced airflow can shorten the life of the system's major components, such as motor, limits, elements, heat relays, evaporator coil or compressor. Consequently, we recommend that the return air duct system have only one filter location. For systems with a return air filter grill or multiple filter grills, can have a filter installed at each of the return air openings.

If adding high efficiency filters or electronic air filtration systems, it is very important that the air flow is not reduced. If air flow is reduced the overall performance and efficiency of the unit will be reduced. It is strongly recommended that a professional installation technician is contacted to ensure installation of these such filtration systems are installed correctly.

**IMPORTANT:** Do not double filter the return air duct system. Do not filter the supply air duct system. This will change the performance of the unit and reduce airflow.

#### **⚠ WARNING**

Do not operate the system without filters. A portion of the dust entrained in the air may temporarily lodge in the duct and run at the supply registers. Any circulated dust particles could be heated and charred by contact with the air handler elements. This residue could soil ceilings, walls, drapes, carpets and other articles in the house.

Soot damage may occur with filters in place, when certain types of candles, oil lamps or standing pilots are burned.

### 7.2 Filter Installation Dimensions

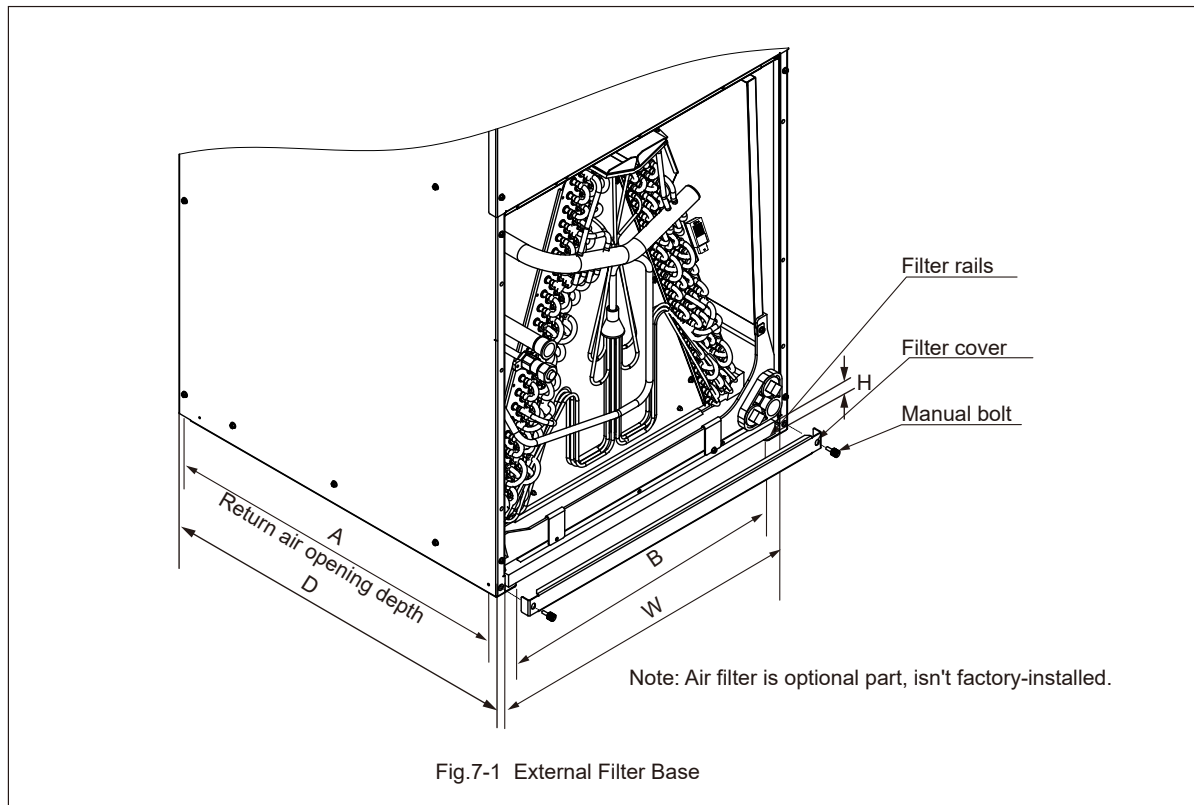

#### Dimensional Data

Model	Filter Size in [mm]	"W" in [mm]	"D" in [mm]	"H" in [mm]	Return width "A" in	Return length Model "B" in
24	16X20 [406X508]	16.8 [426]	20.4 [518]	1 [25.4]	19.6	14.8
36	18X20 [457X508]	18.3 [466]	21.6 [548]	1 [25.4]	20.8	16.3
48/60/61	20X22 [508X559]	20.7 [526]	23.9 [608]	1 [25.4]	23	18.8

## AIR FILTER REMOVAL

1. Remove bolts manually, remove air filter recover. See in Fig.7-1.
2. Hold the edge of the air filter and extract out.
3. Clean the air filter (Vacuum cleaner or pure water may be used to clean the air filter. If the dust accumulation is too heavy, use soft brush and mild detergent to clean it and dry out in cool place). See in Fig.7-2.
4. Install new filter so that the arrow on the filter is in the same direction as airflow.

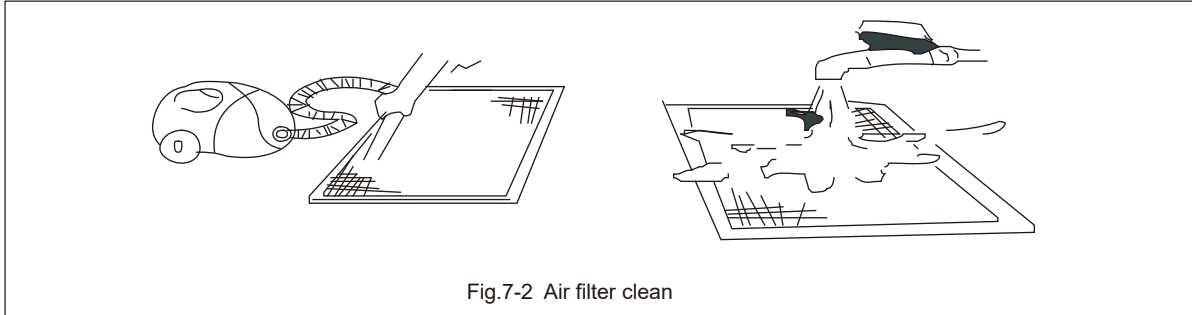

Fig.7-2 Air filter clean

## 8 DRAIN PIPE INSTALLATION

Consult local codes for specific requirements.

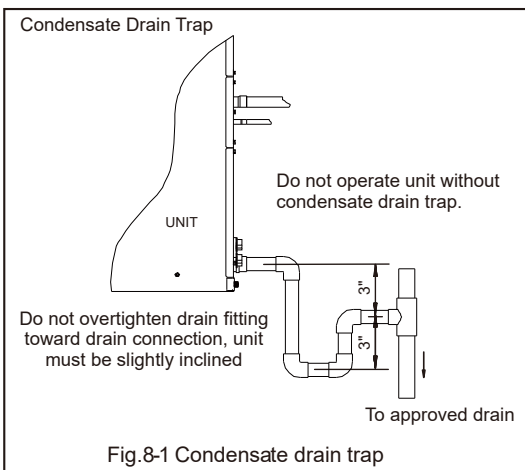

Fig.8-1 Condensate drain trap

### IMPORTANT:

1. When making drain fitting connections to the drain pan, use a thin layer of Teflon paste, silicone or Teflon tape and install, hand tighten.
  2. When making drain fitting connections to drain pan, do not overtighten. Over tightening fittings can split pipe connections on the drain pan.
- Install drain lines so they do not block service access to front of the unit. Minimum clearance of 24 inches is required for filter, coil or blower removal and service access.
  - Do not reduce drain line size less than connection size provided on condensate drain pan. Use 3/4" PVC piping for drain piping connections.
  - Do not connect condensate drain line to a closed or open sewer pipe. Run condensate to an open drain or run line to a safe outdoor area.
  - Make provisions for disconnecting and cleaning of the primary drain line should it become necessary. Install a 3 inch trap in the primary drain line as close to the unit as possible. Make sure that the top of the trap is below connection to the drain pan to allow complete drainage of pan (See Fig. 8-1).

- All drain lines must be pitched downward away from the unit a minimum of 1/8" per foot of line to ensure proper drainage.
  - Make sure unit is level or pitched slightly toward primary drain connection so that water will drain completely from the pan. Up to an additional 1/4" rise over the width or depth for the unit is allowed to create additional sloping towards the drain. Unit must be positioned between level and 1/4" rise, sloping toward the drain connections. See Fig.8-2, Fig.8-3, Fig.8-4, Fig.8-5.
  - Plug the unused drain connection with the plugs provided in the parts bag, using a thin layer of teflon paste, silicone or teflon tape to form a water tight seal.
  - Test condensate drain pan and drain line after installation is complete. Pour water into drain pan, enough to fill drain trap and line. Check to make sure drain pan is draining completely, no leaks are found in drain line fittings, and water is draining from the termination of the primary drain line.
  - Auxiliary drain line should be run to a place where it will be noticeable if it becomes operational. Homeowner should be warned that a problem exists if water should begin running from the auxiliary drain line.
- The drain line should be insulated where necessary
- to prevent sweating and damage due to condensate forming on the outside surface of the line.
  - Be sure to insulate the drain piping and drain socket since condensation may cause water leakage.
  - Be sure to install a drain trap at the drain outlet since the inside of the unit is at negative pressure relative to atmospheric pressure during operation.

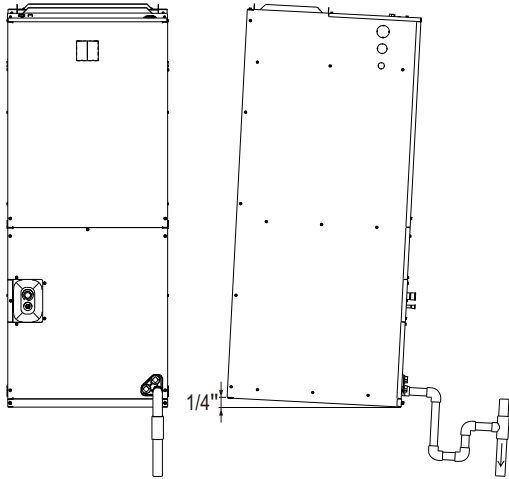

Fig.8-2 Vertically upflow view

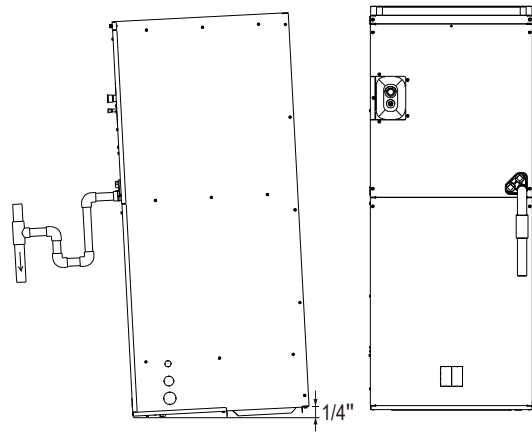

Fig.8-3 Vertically downflow view

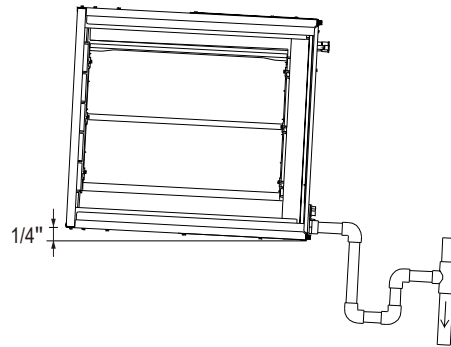
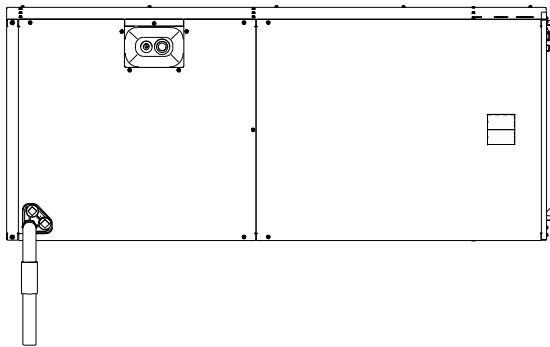

Fig.8-4 Horizontally right view

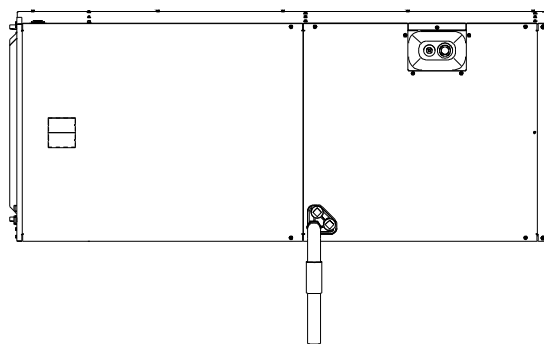
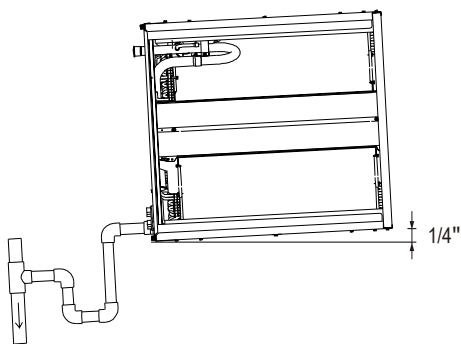

Fig.8-5 Horizontally left view

## 9 ELECTRICAL WIRING

In the U.S.A., wiring must conform with current local codes and the current National Electric Code (NEC). In Canada, wiring must conform with current local codes and the current Canadian Electrical Code (CEC).

### **⚠ DANGER**

Installation and servicing of air conditioning equipment can be hazardous due to internal refrigerant pressure and live electrical components. Only trained and qualified service personnel should install or service this equipment. Installation and service performed by unqualified persons can result in property damage, personal injury, or death.

Risk of electrical shock. Disconnect all remote power supplies before installing or servicing any portion of the system. Failure to disconnect power supplies can result in property damage, personal injury, or death.

### 9.1 Control Wiring

#### **⚠ CAUTION**

Conventional 24VAC non-communicating thermostat control wires must be connected reliably and protected by insulation.

The unused wires should be insulated, and the copper wires should not be exposed.

Sharp metal edges can cause injury. When installing the unit, use care to avoid sharp edges.

Avoid sharp metal edges for wires to prevent wear, or it may lead to short circuit or electric leakage and cause danger.

#### **💡 NOTE**

Electrostatic discharge can affect electronic components. Take care during unit installation and service to protect the unit's electronic controls. Precautions will help to avoid control exposure to electrostatic discharge by putting the unit, the control and the technician at the same electrostatic potential. Touch hand and all tools on an unpainted unit surface before performing any service procedure to neutralize electrostatic charge.

Low voltage control connections are made to low voltage pigtailed extending from top of air handler (upflow position - see Fig 2-1).

Do not connect the power cords (high voltage) to the Conventional 24VAC non-communicating thermostat control wires (low voltage), otherwise it will damage the control board.

Conventional 24VAC non-communicating thermostat control wires should be fixed well. Otherwise, the connectors may be loose or the terminal may be damaged when they are pulled.

Power cords and conventional 24VAC non-communicating thermostat control wires must be separated from each other with a distance of more than 2 inches. Otherwise, the communication may be abnormal.

The conventional 24VAC non-communicating thermostat control wires connectors are SELV connection points.

#### 9.1.1 Low voltage wires maximum length

Table 9-1 defines the maximum total length of low voltage wires from the outdoor unit to the indoor unit and the indoor unit to the thermostat.

Conventional 24VAC Non-communicating Control Wires	
Wires Size	Max Wires Length
18 AWG	150 ft.
16 AWG	225 ft.

Table 9-1

#### **💡 NOTE**

Before proceeding with electrical connections, make certain that voltage, frequency, and phase correspond to that specified on rating plate. Also, check to be sure that the service provided by utility is sufficient to handle additional load imposed by this equipment.

Refer to unit wiring label for proper field high- and low-voltage wiring. Make all electrical connections in accordance with NEC and any local codes or ordinances that might apply.

Please connect the wire following the wiring diagram. The rating power of the transformer is limited. If you connect some additional loads/parts such as zoning panel to it, it may cause component damage. Consult with a professional service technician when connecting additional loads/parts to transformer.

All units shipped from factory are wired for 240VAC transformer operation. If the input voltage is 208 V, please change the transformer tap by taking the red wire to 208VAC terminal.

#### 9.1.2 Low voltage wires connections

Low-voltage wires include indoor unit connect with outdoor unit and the indoor unit connect with the thermostats.

##### 1. Remove the electrical control box panel.

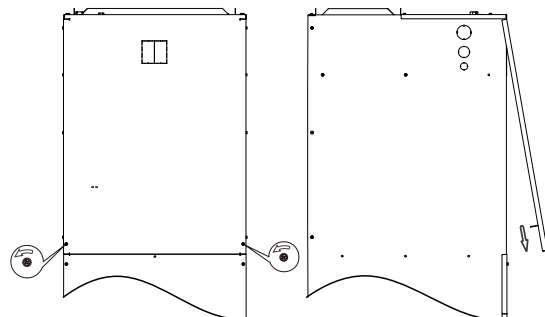

Fig.9-1

**2. Wires connections diagram.**

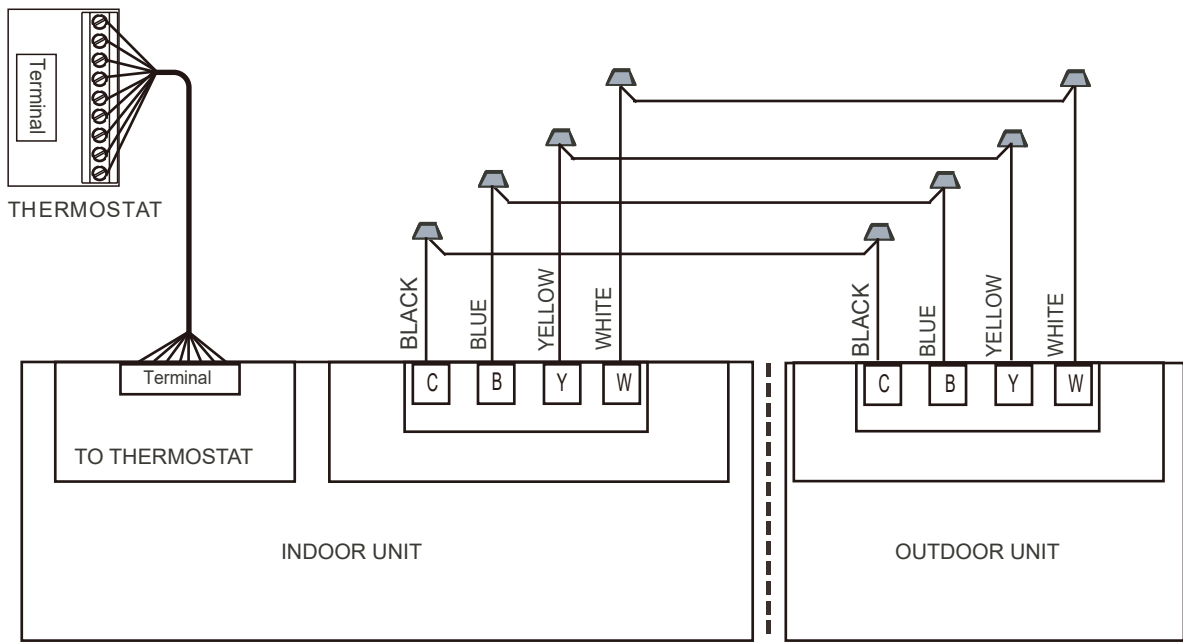

Fig.9-2

**3. Low voltage wires connections with outdoor unit.**

- Connect the conventional 24VAC non-communicating thermostat control wires (C, B, Y and W) to the four field supplied wires.

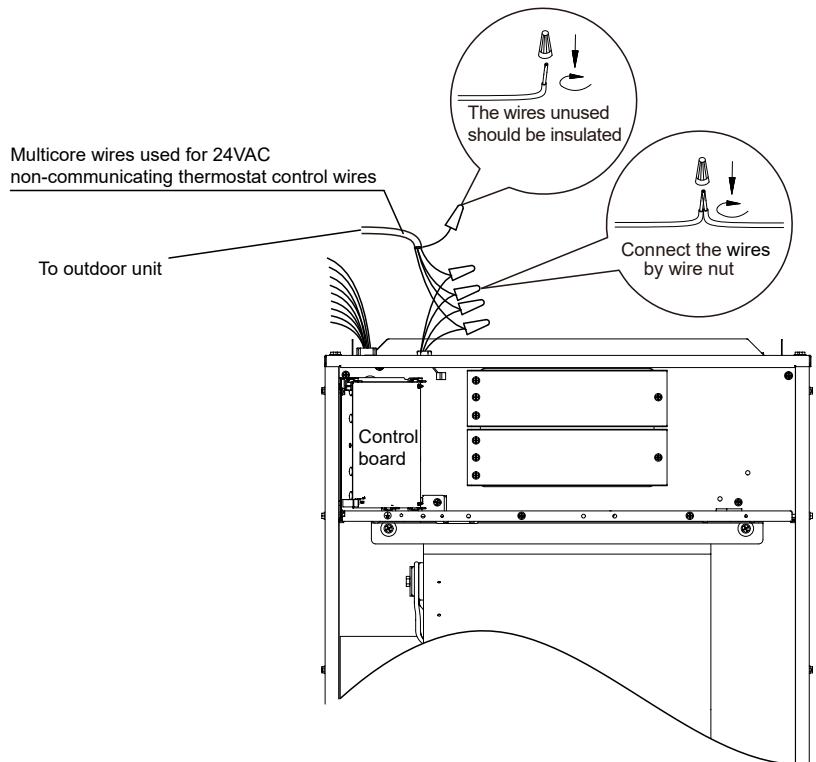

Fig.9-3

#### 4. Low voltage wires connections with thermostat.

4.1 Connect the Control communication cables by wire nut.

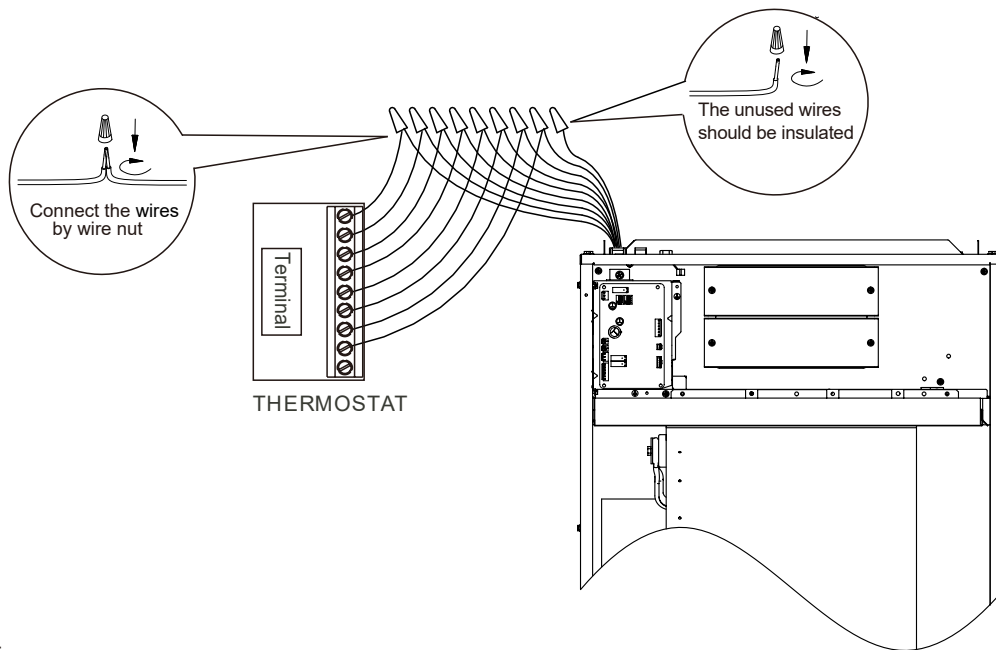

Fig.9-4

4.2 Wiring diagram of the thermostat.

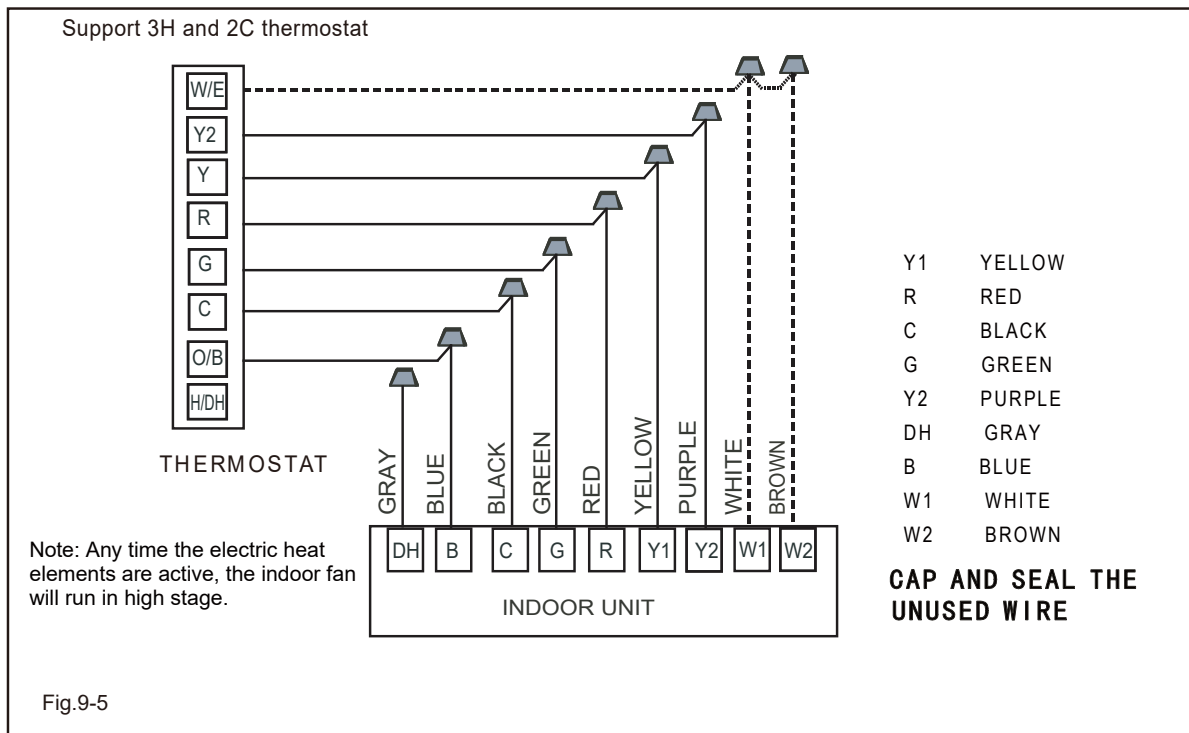
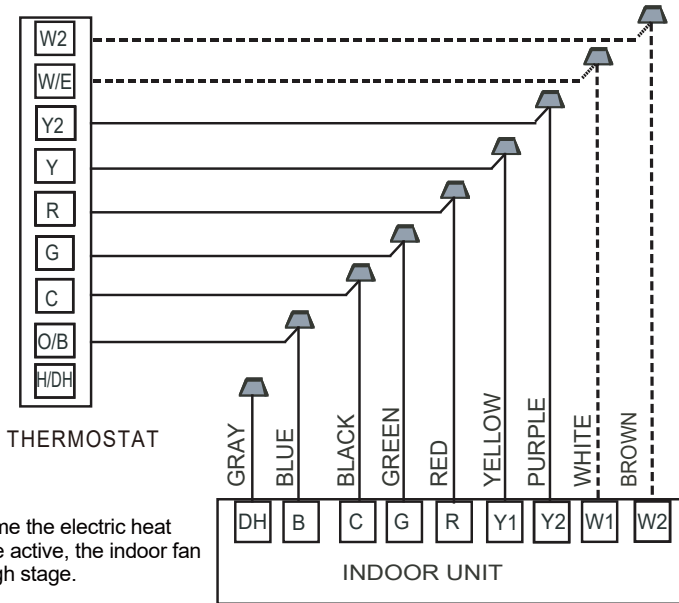

Fig.9-5

Wiring for 4H and 2C thermostat



- Y1 YELLOW
- R RED
- C BLACK
- G GREEN
- Y2 PURPLE
- DH GRAY
- B BLUE
- W1 WHITE
- W2 BROWN

Note: Any time the electric heat elements are active, the indoor fan will run in high stage.

**CAP AND SEAL THE UNUSED WIRE**

Fig.9-6

Wiring for 3H and 1C thermostat

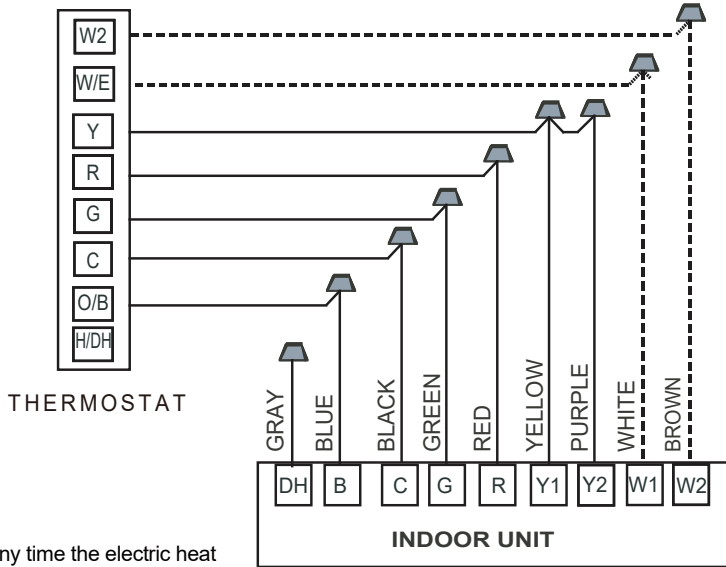

- Y1 YELLOW
- R RED
- C BLACK
- G GREEN
- Y2 PURPLE
- DH GRAY
- B BLUE
- W1 WHITE
- W2 BROWN

Note: Any time the electric heat elements are active, the indoor fan will run in high stage.

**CAP AND SEAL THE UNUSED WIRE**

Fig.9-7

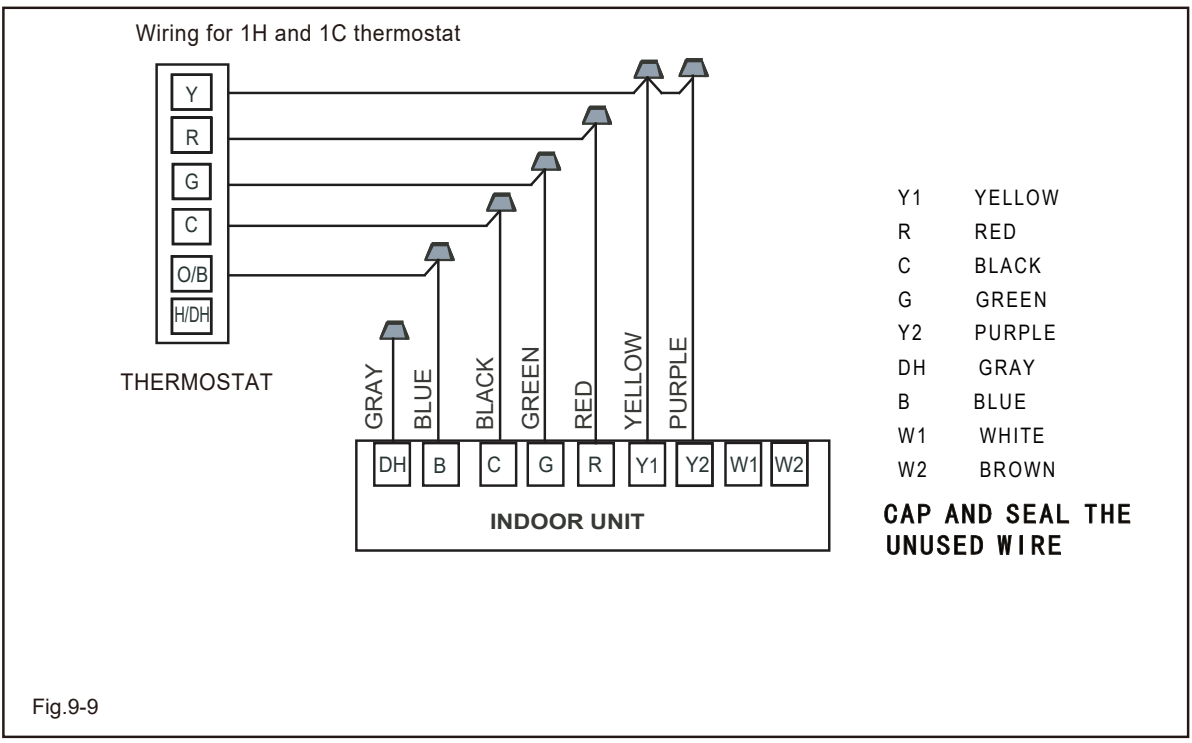
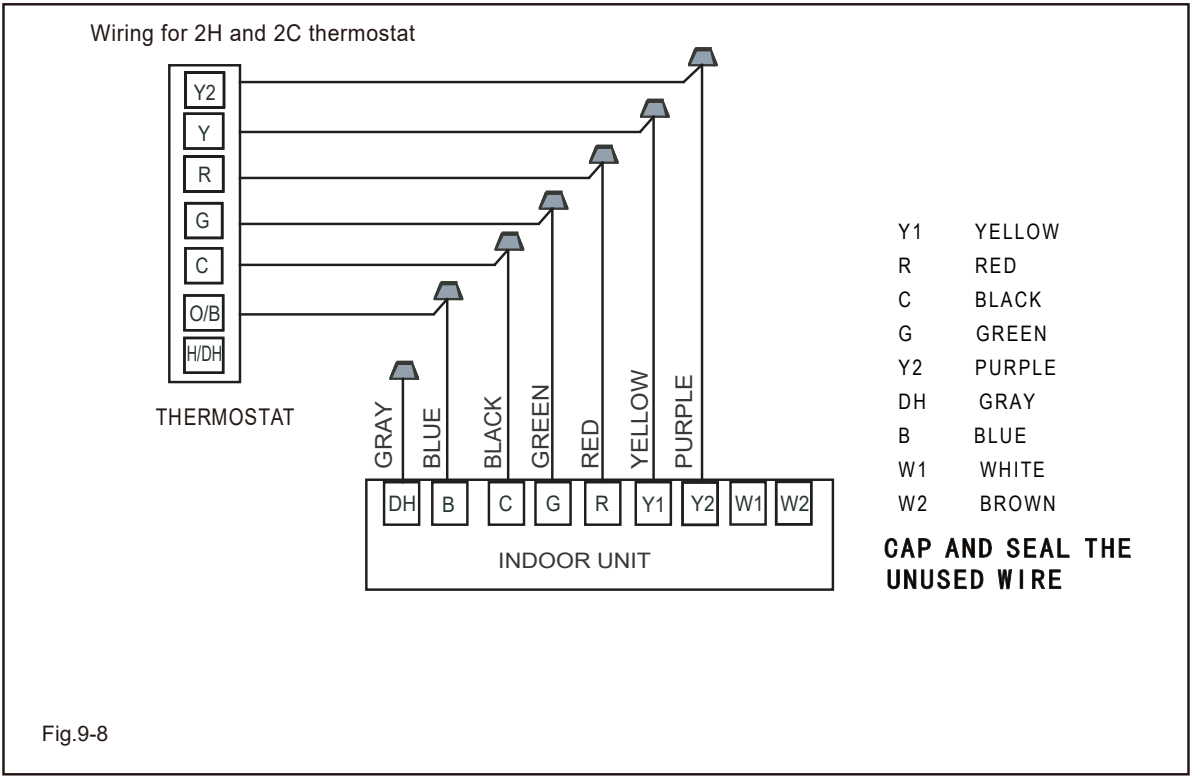

Wiring for 2H and 1C thermostat

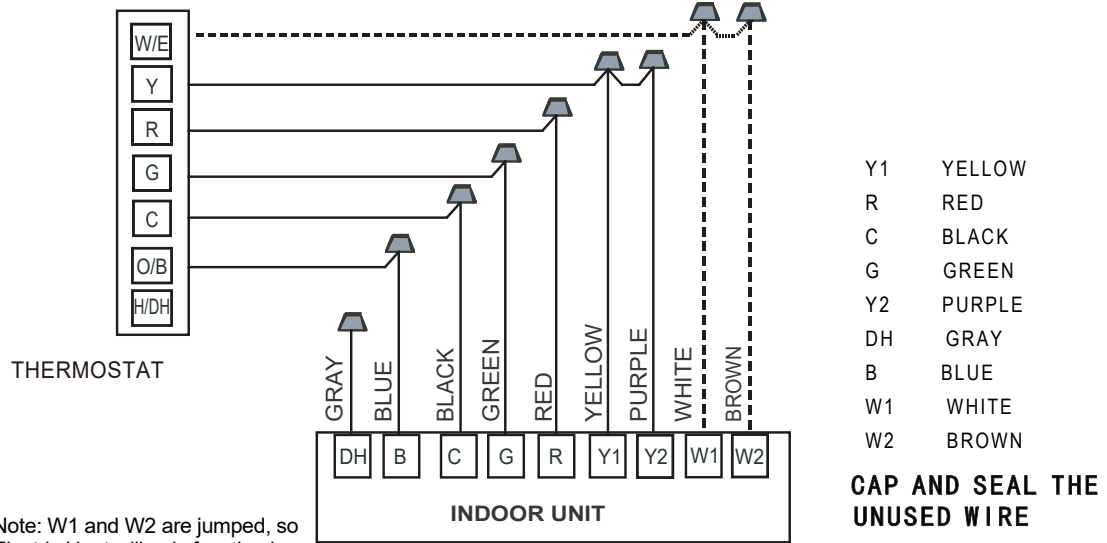

Fig.9-10

## 9.2 Power Wiring

In the U.S.A., wiring must conform with current local codes and the current National Electric Code (NEC). In Canada, wiring must conform with current local codes and the current Canadian Electrical Code (CEC).

### **⚠ WARNING**

Installation and servicing of air conditioning equipment can be hazardous due to internal refrigerant pressure and live electrical components. Only trained and qualified service personnel should install or service this equipment. Installation and service performed by unqualified persons can result in property damage, personal injury, or death.

Risk of electrical shock. Disconnect all remote power supplies before installing or servicing any portion of the system. Failure to disconnect power supplies can result in property damage, personal injury, or death.

Fire Hazard. Use of aluminum wire with this product may result in a fire, causing property damage, severe injury or death. Use copper wire only with this product.

Can cause injury or death. Unit must be properly grounded in accordance with national and local codes.

Natural grounding poles embedded in the ground can be used, but do not connect the ground wire to the following locations:

- (a) Pipes of flammable or explosive gases, which may otherwise lead to an explosion or fire.
- (b) Insulated plastic pipes, otherwise there is no grounding effect.
- (c) Telephone line or lightning rod, otherwise it will be dangerous for increasing the ground potential during lightning strikes.

During installation, testing, servicing, and troubleshooting of this product, it may be necessary to work with live electrical components. Failure to follow all electrical safety precautions when exposed to live electrical components could result in death or serious injury.

### **⚠ CAUTION**

Sharp metal edges can cause injury. When installing the unit, use care to avoid sharp edges.

Avoid sharp metal edges for wires to prevent wear, or it may lead to short circuit or electric leakage and cause danger.

Wires should be fixed well. Otherwise, the connectors may be loose or the terminal may be damaged when they are pulled.

### **💡 NOTE**

Electrostatic discharge can affect electronic components. Take care during unit installation and service to protect the unit's electronic controls. Precautions will help to avoid control exposure to electrostatic discharge by putting the unit, the control and the technician at the same electrostatic potential. It is strongly recommended to contact a professional installation technician to ensure the correct installation of such filtration systems.

Do not add phase junction capacitors, otherwise it may cause serious damage to the product.

Do not start the unit before installing pipes. Otherwise, the compressor will be damaged.

### 9.2.1 High Voltage Power Supply

Ensure that the supply voltage to the unit is within the acceptable range, not exceeding 10% over the rated voltage or 10% under the rated voltage.

### 9.2.2 Power Wire Sizes, Disconnect Switch and Breaker

Refer to the unit nameplate for minimum circuit ampacity, and maximum fuse or circuit breaker (HACR TYPE per NEC). Install power cords and properly sized disconnect switch and breaker.

### 9.2.3 Power Wire Connections

Power wiring may be connected to either the right, side or top. Three 7/8", 1-3/8", 1-3/4" dia. concentric knock-outs are provided for connection of power wiring to unit.

Power wires by splicing follow as Fig.9-11

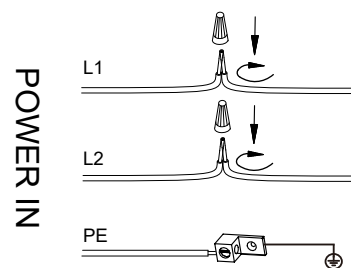

Fig.9-11

Ground lug(s) are located close to wire entrance on right side of unit (up-flow). Connect the ground wire from the power supply to the unit ground lug connection. as Fig. 9-11.

### **⚠ WARNING**

The unit must be permanently grounded. Failure to do so can result in electrical shock causing personal injury or death.

## 9.3 Alarm Wiring

### 9.3.1 Wiring Diagram

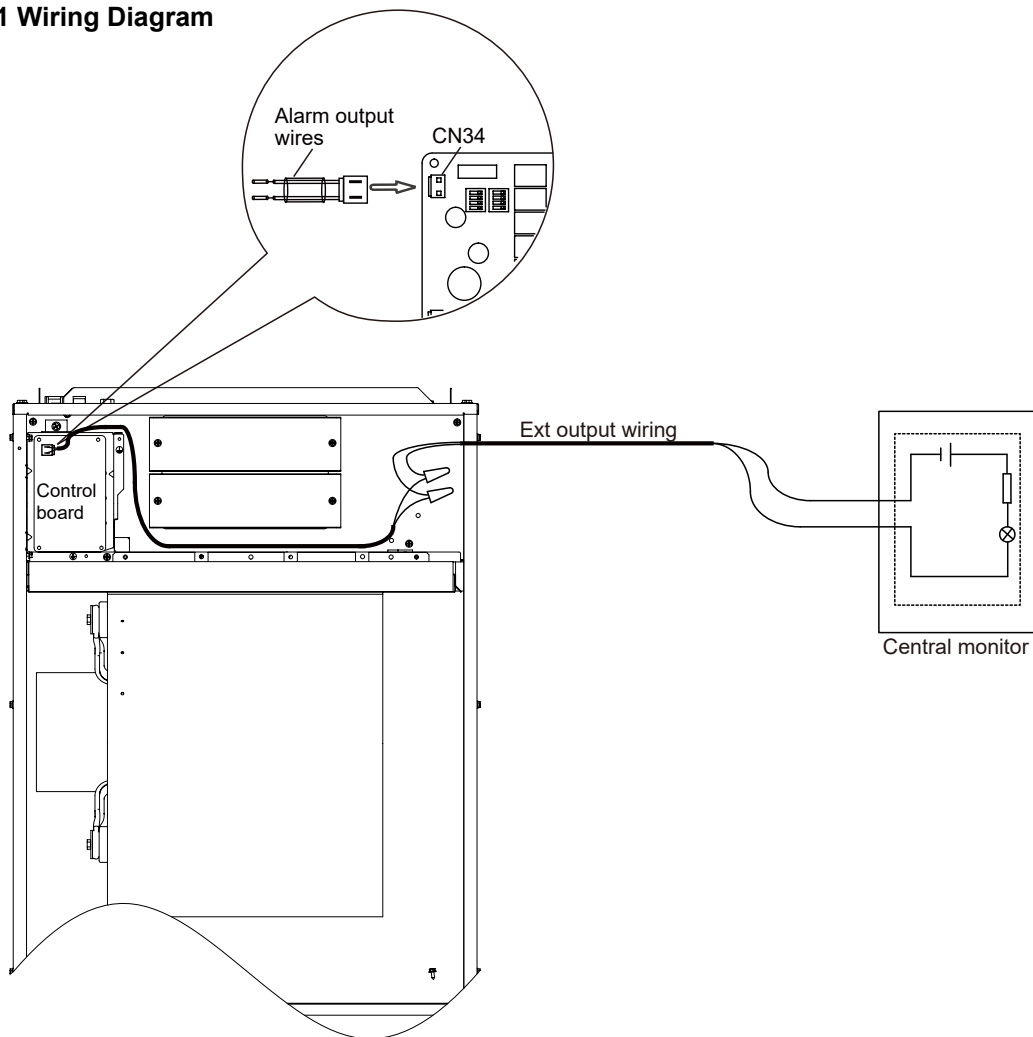

Fig.9-12

**Note:**

The remote control of the internal circuit is for reference only, the user can change the wiring mode according to the actual situation.

The Alarm port is a switch that closes when the refrigerant leakage protection is triggered. The user can choose the appropriate remote.

### 9.3.2 Installation

Step 1 : Take out the Alarm wires from the accessory bag and plug it into CN34 on the control board (see Fig.9-12).

Step 2 : Connect the Alarm wires with the central monitor (see Fig.9-12).

### **CAUTION**

The rated operating condition of ALARM is 24 VAC/1A or 30 VDC/1A or 250 VAC/1A.

The type of wiring for ext output should use cables of AWG 18 (Min. AWG 18).

## 9.4 Electric Heater Kit

### 9.4.1 Electric heater kit breaker information

NO.	Kit	Description	Breaker	Ref.Air Handler Use
1	EHK-05*	5 kW Heater	Max. 240 V, 30 A, 2 P	24,36,48,60,61
2	EHK-08*	7.5 kW Heater	Max. 240 V, 50 A, 2 P	24,36,48,60,61
3	EHK-10*	10 kW Heater	Max. 240 V, 60 A, 2 P	24,36,48,60,61
4	EHK-15*	15 kW Heater, double Breaker panel	Max. 240 V, 50 A, 2 P	36,48,60,61
5	EHK-20*	20 kW Heater, double Breaker panel	Max. 240 V, 60 A, 2 P	36,48,60,61

Table 9-2

Note: Heater model number digits "\*\*\*" : A,B,C,D,E,F,etc.

### 9.4.2 Electric heater kits installation information

#### Requirements

Installation of electric heat sections must conform with standard in National Fire Protection Association (NFPA) Standard for Installation of Air Conditioning and Ventilation Systems NFPA No. 90A, Standard for the Installation of Residence Type Warm Air Heating and Air Conditioning System NFPA No. 90B, manufacturer's installation instructions and local municipal building codes. Heaters are approved for clearance to combustible materials as listed on heater rating plate. Accessibility and service clearances must take precedence over fire protection clearances. All wiring must conform with local codes and the National Electric Code (NEC). ANSI-C1-1978.

#### ⚠ CAUTION

As with any mechanical equipment, contact with sharp sheet metal edges can result in personal injury. Take care while handling this equipment and wear gloves and protective clothing.

The circuit breaker of electric heater kit in indoor unit cannot be used as air switch for power cables and cannot be operated by users. Maintenance personnel need to disconnect the main switch before servicing.

If install a third-party electric heater kit, ensure that all components used of the electric heater kit meet the A2L class flammable refrigerant regulations.

#### Installation

#### ⚠ WARNING

Supply circuit power wiring must be 167 °F (75 °C) minimum copper conductors only. See Table 9-3 for Electrical Data in this section for ampacity, wire size and circuit protector requirement. Supply circuit protective devices may be either fuses or "HACR" type circuit breakers.

#### 💡 NOTE

Installing the electric heater before installing the air outlet duct system.

Finished view (for reference only).

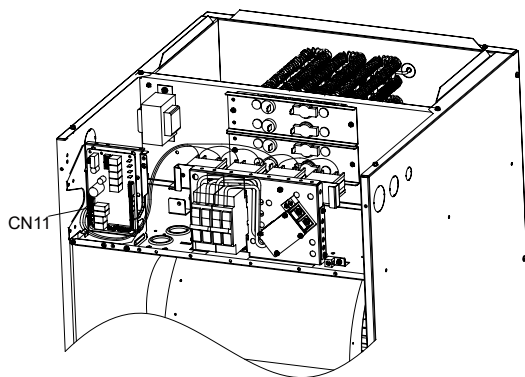

Fig.9-13

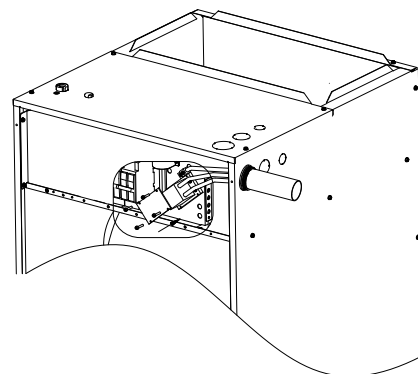

Fig.9-14

Please refer to the manual of electric heater kit for detailed installation and wiring instructions.

### 9.4.2 Electric Heater Kit Electrical Data (only Electric Heat)

Heater Kit Model Used	Air Handler Model	Electric Heat (kW)	Min. Circuit Ampacity		Max. Fuse or Breaker (HACR) Ampacity		Minimum Heating Blower Speed				
			240 V	208 V	240 V	208 V	1	2	3	4	5
EHK-05*	24	5	26.1	22.6	30	25	●	●	●	●	●
EHK-08*		7.5	39.1	33.9	40	35	X	X	●	●	●
EHK-10*		10	52.1	45.2	60	50	X	X	●	●	●
EHK-05*	36	5	26.1	22.6	30	25	●	●	●	●	●
EHK-08*		7.5	39.1	33.9	40	35	X	●	●	●	●
EHK-10*		10	52.1	45.2	60	50	X	X	●	●	●
EHK-15*		15	52.1/26.1	45.2/22.6	60/30	50/25	X	X	●	●	●
EHK-20*		20	52.1/52.1	45.2/45.2	60/60	50/50	X	X	X	●	●
EHK-05*	48	5	26.1	22.6	30	25	●	●	●	●	●
EHK-08*		7.5	39.1	33.9	40	35	●	●	●	●	●
EHK-10*		10	52.1	45.2	60	50	X	●	●	●	●
EHK-15*		15	52.1/26.1	45.2/22.6	60/30	50/25	X	X	●	●	●
EHK-20*		20	52.1/52.1	45.2/45.2	60/60	50/50	X	X	X	●	●
EHK-05*	60	5	26.1	22.6	30	25	X	X	●	●	●
EHK-08*		7.5	39.1	33.9	40	35	X	X	●	●	●
EHK-10*		10	52.1	45.2	60	50	X	X	●	●	●
EHK-15*		15	52.1/26.1	45.2/22.6	60/30	50/25	X	X	●	●	●
EHK-20*		20	52.1/52.1	45.2/45.2	60/60	50/50	X	X	X	●	●
EHK-05*	61	5	26.1	22.6	30	25	X	X	●	●	●
EHK-08*		7.5	39.1	33.9	40	35	X	X	●	●	●
EHK-10*		10	52.1	45.2	60	50	X	X	●	●	●
EHK-15*		15	52.1/26.1	45.2/22.6	60/30	50/25	X	X	●	●	●
EHK-20*		20	52.1/52.1	45.2/45.2	60/60	50/50	X	X	X	●	●

Table 9-3

Note: Heater model number digits "\*" : A,B,C,D,E,F,etc.

#### NOTE

Heat kit suitable for AHU 4-way position installation.

Heat pump systems require a specified airflow. Each ton of cooling requires between 350 and 450 cubic feet of air per minute(CFM), or 400 CFM nominally.

### 9.4.3 Electric Heater Kit Electrical Data (Electric Heat combines with Indoor motor)

Heater Kit Model Used	Air Handler Model	Electric Heat (kW)	Min. Circuit Ampacity		Max. Fuse or Breaker (HACR) Ampacity		Minimum Heating Blower Speed				
			240 V	208 V	240 V	208 V	1	2	3	4	5
EHK-05*	24	5	28.7	25.2	30	30	●	●	●	●	●
EHK-08*		7.5	41.7	36.5	45	40	X	X	●	●	●
EHK-10*		10	54.7	47.8	60	50	X	X	●	●	●
EHK-05*	36	5	29.4	25.9	30	30	●	●	●	●	●
EHK-08*		7.5	42.4	37.2	45	40	X	●	●	●	●
EHK-10*		10	55.4	48.5	60	50	X	X	●	●	●
EHK-15*		15	55.4/26.1	48.5/22.6	60/30	50/25	X	X	●	●	●
EHK-20*		20	55.4/52.1	48.5/45.2	60/60	50/50	X	X	X	●	●
EHK-05*	48	5	30.6	27.1	35	30	●	●	●	●	●
EHK-08*		7.5	43.6	38.4	45	40	●	●	●	●	●
EHK-10*		10	56.6	49.7	60	50	X	●	●	●	●
EHK-15*		15	56.6/26.1	49.7/22.6	60/30	50/25	X	X	●	●	●
EHK-20*		20	56.6/52.1	49.7/45.2	60/60	50/50	X	X	X	●	●
EHK-05*	60	5	31.7	28.2	35	30	X	X	●	●	●
EHK-08*		7.5	44.7	39.5	45	40	X	X	●	●	●
EHK-10*		10	57.7	50.8	60	60	X	X	●	●	●
EHK-15*		15	57.7/26.1	50.8/22.6	60/30	60/25	X	X	●	●	●
EHK-20*		20	57.7/52.1	50.8/45.2	60/60	60/50	X	X	X	●	●
EHK-05*	61	5	31.7	28.2	35	30	X	X	●	●	●
EHK-08*		7.5	44.7	39.5	45	40	X	X	●	●	●
EHK-10*		10	57.7	50.8	60	60	X	X	●	●	●
EHK-15*		15	57.7/26.1	50.8/22.6	60/30	60/25	X	X	●	●	●
EHK-20*		20	57.7/52.1	50.8/45.2	60/60	60/50	X	X	X	●	●

Table 9-4

Note: Heater model number digits "\*" : A,B,C,D,E,F,etc.

#### NOTE

Heat kit suitable for AHU 4-way position installation.

Heat pump systems require a specified airflow. Each ton of cooling requires between 350 and 450 cubic feet of air per minute(CFM), or 400 CFM nominally.

## 10 SETTING

Check whether the DIP switch is correct according to the wiring nameplate after the electrical wiring is complete. SW6-1,2 is used to set the blower speed. The factory default settings of different models as shown in the table 10-1. The DIP switch can be adjusted according to different speed requirements. There are two blower speed control modes: 1-Stage Controller and 2-Stage Controller, and the two modes correspond to different speed control. In 1-Stage Controller, The blower speed of cooling operation and heating operation is same. When there is G or Y1 signal, the blower running at lower speed, when there is W/W1/W2 signal, running at high speed. In 2-Stage Controller (Only used for 61K), the speed of cooling operation and heating operation is different. When there is G or Y1 signal, the blower runs at lower speed, when there is Y1+Y2 or W/W1/W2 signal, it runs at high speed. The anti-cool air function is disabled by factory default. You can set DIP switch SW6-3 to enable it.

1-Stage Controller				
	DIP Switch	Y1 or G	W/W1/W2	
SW6-1,2 Fan Speed Taps		2	3	
		3	4	
		4	5	
		5	5	
2-Stage Controller				
	DIP Switch	Y1 or G (MIN)	Y1+Y2 or W/W1/W2 (MAX)	
SW6-1,2 Fan Speed Taps		Cool	1	2
		Heat	1	3
		Cool	1	3
		Heat	2	4
		Cool	2	4
		Heat	3	5
		Cool	3	5
		Heat	3	5
Not Used				
SW6-3,4		Factory Default		
SW7-1,2 SW7-3,4		Factory Default		

Table 10-1

## 11 SERVICE

### 11.1 Error Code and Troubleshooting

The unit LED will flash when the unit is abnormal. Security consideration, the outdoor unit shutdown until the abnormal condition is corrected.

NO.	LED1 Status	Description
1	3Flash/Cycle	R454B refrigerant sensor fault
2	4Flash/Cycle	R454B refrigerant sensor communication fault
3	Keep Flashing	R454B refrigerant leakage protection in indoor unit
4	8Flash/Cycle	R454B refrigerant sensor over service life
NO.	LED1 Status	Possible Reason
1	3Flash/Cycle	R454B refrigerant sensor failure
2	4Flash/Cycle	Wiring error/ R454B refrigerant sensor failure
3	Keep Flashing	R454B refrigerant leakage/ R454B refrigerant sensor failure
4	8Flash/Cycle	R454B refrigerant sensor over service life/R454B refrigerant sensor failure

Table 11-1

#### NOTE

The flash interval is 2 seconds. For example, 3 Flash / Cycle is flash three times every 2 seconds.

#### CAUTION

If the refrigerant sensor reaches the end of its service life, it should be replaced by an authorized person.

If a leak is detected, follow safety procedures: Immediately evacuate all persons from the room or space, and contact the qualified licensed service personnel to advise them that a refrigerant R454B (A2L class flammable refrigerant) leak has occurred.

## 11.2 TXV Replacement Information

### NOTE

The TXV replacement options noted in this sheet supersede those in the installation guide.

#### TXV-Replace Steps

- Step 1: Remove the screws and front coil panel.
- Step 2: Remove the rubber plugs from the liquid and vapor lines.
- Step 3: Unwrap copper strap on sensing bulb and dismount the sensing bulb.
- Step 4: Using a backup wrench to loose the nut of TXV.
- Step 5: Take off TXV mounting clip ring.
- Step 6: Use wet rag to protect pipe in coil, Al-Copper transition section (The black section of vapor line).
- Step 7: Braze and take off two pipes from TXV. Be extra care not to overheat the pipes, and keep nitrogen flowing While brazing.
- Step 8: Wrap the new TXV with a wet rag to prevent overheating. connect and braze pipe to new TXV. And keep nitrogen flowing While brazing.
- Step 9: Replace a new sealing ring to the pipe joint, connect the TXV with pipe joint and tight the nut to 22 ( $\pm 2$ ) ft-lb.
- Step 10: Allow tube to cool and pressurize line sets with 250 PSI of nitrogen to check for leaks.
- Step 11: Use the supplied copper straps to secure the TXV sensing bulb on top of the vapor line as pictured.
- Step 12: Use clip ring to hold TXV on mounting plate.
- Step 13: Insulate the entire vapor line and sensing bulb. It is also recommended to insulate the TXV and liquid line to prevent condensation in hot humid environments.
- Step 14: Replace the front coil metal plate and secure in place.
- Step 15: Follow the steps in the installation guide for vacuum requirements and system start up procedures.
- Step 16: Allow system to run for an additional 10 minutes to verify the subcooling and superheat readings.

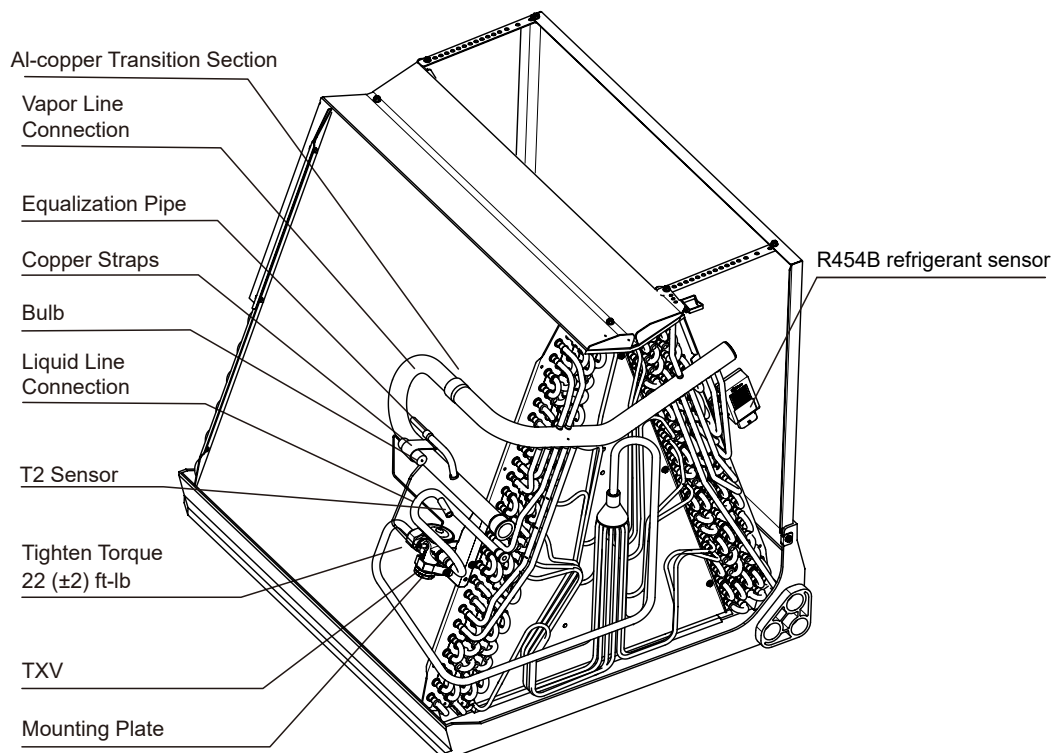

Table 11-2 . TXV specification.

Model	R454B TXV
24, 36	3 Ton
48	4 Ton
60, 61	5 Ton

## 12 DISPOSAL

Comply with national regulations.

Components and accessories from the units are not part of ordinary domestic waste.

Complete units , compressors, motors etc. are only to be disposed of via qualified disposal specialists.

This unit uses flammable refrigerant R454B. Please contact the dealer when you want to dispose of this unit. Law requires that the collection, transportation and disposal of refrigerants must conform with the regulations governing the collection and destruction of hydrofluorocarbons.