

# **INSTALLER'S GUIDE**

## **FAN COIL UNIT**

APARTMENT FAN COIL UNIT  
MPCP\*N10\*, MPCE\*N10\*  
R454B

# CONTENTS

---

## 1 SAFTY

- 1.1 Safety Signs ..... 01
- 1.2 Safety Precaution..... 01

## 2 INTRODUCTION..... 16

## 3 INSTALLATION

- 3.1 Refrigerant Charge and Room Area Limitations..... 08
- 3.2 Refrigerant Line ..... 11
- 3.3 Installation Instructions ..... 12

## 4 START-UP ..... 19

## 5 SEQUENCE OF OPERATION..... 19

## 6 CARE AND MAINTENANCE ..... 19

## 7 AIRFLOW PERFORMANCE TABLES ..... 20

---

This document is customer property and is to remain with this unit.  
 These instructions do not cover all the different variations systems nor does it provide for every possible contingency to be met in connection with installation.  
 All phases of this installation must comply with national state and local codes. If additional information is required, please contact your local distributor.

# 1 SAFETY

## 1.1 Safety Signs



This is a safety alert symbol. When you see this symbol on labels or in manuals, be alert to the potential for personal injury.



This is an attention alert symbol. When you see this symbol on labels or in manuals, be alert to the potential for personal injury.

### **WARNING**

Indicates a hazardous situation which, if not avoided, could result in death or serious injury.

### **CAUTION**

Indicates a hazardous situation which, if not avoided, could result in minor to moderate injury.



### **NOTICE**

Indicates a situation that may cause damage to the equipment or loss of property.

### **NOTE**

Is used to address practices not related to personal injury.

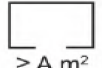
## Explanation of symbols displayed on the unit

	<b>WARNING</b>	This symbol shows that this appliance used a mild flammable refrigerant. If the refrigerant is leaked and exposed to an external ignition source, there is a risk of fire.
	<b>WARNING</b>	This symbol shows that appliance shall be installed, operated and stored in a room with a floor area not less than the minimum room area.
	<b>CAUTION</b>	This symbol shows that the operation manual should be read carefully.
	<b>CAUTION</b>	This symbol shows that a service personnel should be handling this equipment with reference to the installation manual.
	<b>CAUTION</b>	This symbol shows that information is available such as the operating manual or installation manual.

## 1.2 Safety Precautions

### WARNING

Disconnect all power to unit before installing or servicing. More than one disconnect switch may be required to de-energize the equipment. Hazardous voltage can cause server personal injury or death.

### WARNING

If removal of the blower assembly is required, all disconnect switches supplying power to the equipment must be de-energized and locked (if not in sight of unit) so the field power wires can be safely removed from the blower assembly. Failure to do so may cause electrical shock resulting in personal injury or death.

### WARNING

The unit must be permanently earthed. Failure to do so may result in electrical shock causing personal injury or death.

### WARNING

Because of possible damage to equipment or personal injury, installation, service, and maintenance should be performed by a trained, qualified service personnel. Consumer service is recommended only for filter cleaning/replacement. Never operate the unit with the access panels removed.

### WARNING

These instructions are intended as an aid to qualified, licensed service personnel for proper installation, adjustment and operation of this unit. Read these instructions thoroughly before attempting installation or operation. Failure to follow these instructions may result in improper installation, adjustment, service or maintenance, possibly resulting in fire, electrical shock, property damage, personal injury or death.

### WARNING

**PROPOSITION 65:** This appliance contains fiberglass insulation. Respirable particles of fiberglass are known to State of California to cause cancer.

All manufacturer products meet current federal OSHA Guidelines for safety. California Proposition 65 warnings are required for certain products, which are not covered by the OSHA standards.

### WARNING

California's Proposition 65 requires warnings for products sold in California that contain or produce any of over 600 listed chemicals known to the State of California to cause cancer or birth defects such as fiberglass insulation, lead in brass, and combustion products from natural vapor.

All "new equipment" shipped for sale in California will have labels stating that the product contains and/or produces Proposition 65 chemicals. Although we have not changed our processes, having the same label on all our products facilitates manufacturing and shipping. We cannot always know "when, or if" products will be sold in the California market.

You may receive inquiries from customers about chemicals found in, or produced by, some of our heating and air-conditioning equipment, or found in natural vapor used with some of our products. Listed below are those chemicals and substances commonly associated with similar equipment in our industry and other manufacturers.

Glass Wool (Fiberglass) Insulation  
Carbon Monoxide (CO)  
Formaldehyde  
Benzene

More details are available on the following websites: OSHA (Occupational Safety and Health Administration), at [www.osha.gov](http://www.osha.gov) and the State of California's OEHHA (Office of Environmental Health Hazard Assessment), at [www.oehha.org](http://www.oehha.org). Consumer education is important since the chemicals and substances on the list are found in our daily lives. Most consumers are aware that products present safety and health risks, when improperly used, handled and maintained.

### WARNING

The first 6 inches of supply air plenum and ductwork must be constructed of sheet metal as required by NFPA 90B. The supply air plenum or duct must have a solid sheet metal bottom directly under the unit with no openings, registers or flexible air ducts located in it. If flexible supply air ducts are used, they may be located only in the vertical walls of rectangular plenum, a minimum of 6 inches from the solid bottom. Metal plenum or duct may be connected to the combustible floor base, if not, it must be connected to the unit supply duct exposed to the supply air opening from the downflow unit. Exposing combustible (non-metal) material to the supply opening of a downflow unit can cause a fire resulting in property damage, personal injury or death.

## WARNING

Only use this unit in well-ventilated area and ensure unit's airflow inlet and outlet would not be impeded by obstructions. Do not use this unit in the following locations:

Locations with mineral oil.

Locations with saline atmospheres, such as seaside locations.

Locations with sulphurous atmospheres, such as near natural hot springs.

Where high voltage electricity is present, such as in certain industrial locations.

On vehicles or vessels, such as trucks or ferry boats.

Where exposure to oily or very humid air may occur, such as kitchens.

In proximity to sources of electromagnetic radiation, such as high-frequency transmitters or other high strength radiation devices.

## WARNING

Do not use means to accelerate the defrosting process or to clean, other than those recommended by the manufacturer.

The appliance shall be stored in a room that does not have continuously operating ignition sources (for example: open flames, an operating gas appliance or an operating electric heater).

Do not pierce or burn the unit.

Be aware that refrigerants may not contain an odour.

If refrigerant gas leaks during installation, ventilate the area immediately.

Comply with national gas regulations.

## WARNING

This appliance is not intended for use by persons (including children) with reduced physical, sensory or mental capabilities, or persons who lack experience and knowledge, unless they are supervised or have been given instructions concerning the use of the appliance by a person responsible for their safety.

Children should be supervised to ensure that they do not play with the appliance.

Any person who is involved with working on or opening a refrigerant circuit should hold a current valid certificate from an industry-accredited assessment authority, which authorizes their competence to handle refrigerants safely in accordance with an industry recognized assessment credential.

Servicing shall only be performed as recommended by the equipment manufacturer.

Maintenance and repair requiring the assistance of other skilled personnel shall be carried out under the supervision of a person competent in the use of flammable refrigerants.

Prior to beginning work on systems containing flammable refrigerants, safety checks are necessary to minimize the risk of ignition.

## WARNING

When repairing the refrigerating system, comply with the following precautions prior to conducting work on the system:

– shall be undertaken according to controlled procedures so as to minimize the risk of the presence of flammable gases or vapors while the work is being performed.

– All maintenance staff and others working in the local area shall be instructed on the nature of work being carried out. Work in confined spaces shall be avoided.

– The area shall be checked with an appropriate refrigerant detector prior to and during work, to ensure the technician is aware of potentially toxic or flammable environment.

– If any hot work is to be conducted on the refrigerating equipment or any associated parts, appropriate fire extinguishing equipment shall be available and easily accessible. Have a dry powder or CO2 fire extinguisher adjacent to the charging area.

– When carrying out work in relation to a refrigerating system that involves exposing any pipe work, no sources of ignition shall be used in such a manner that it may lead to the risk of fire or explosion. All possible ignition sources, including cigarette smoking, should be kept sufficiently far away from the site of installation, repair, or removal and disposal of the unit, during which refrigerant can possibly be released into the surrounding space. Prior to beginning work, the area around the equipment is to be surveyed to make sure that there are no flammable hazards or ignition risks. "No Smoking" signs shall be clearly displayed.

Ensure that the area is in the open or that it is adequately ventilated before opening the system or conducting any hot work. A degree of ventilation shall continue during the period that the work is carried out. The ventilation should safely disperse any released refrigerant and preferably expel it externally into the surroundings.

Where electrical components are being changed, they shall be fit according to their purpose and to the correct specification. At all times the manufacturer's maintenance and service guidelines shall be followed. If in doubt, consult the manufacturer's technical department for assistance. The following checks shall be applied to installations using flammable refrigerants:

– The actual refrigerant charge is in accordance with the room size within which the refrigerant containing parts are installed;

– The ventilation machinery and outlets are operating adequately and are not obstructed.

– If an indirect refrigerating circuit is being used, the secondary circuit shall be checked for the presence of refrigerant.

– Equipment marking must remain visible and legible. Markings and signs that are illegible shall be corrected.

Refrigerating pipe or components are installed in a position where they are unlikely to be exposed to any substances which may corrode refrigerant containing components, unless the components are constructed of materials that are inherently resistant to corrosion or are suitably protected against corrosion.

Repair and maintenance of electrical components shall include initial safety checks and component inspection procedures. If a fault exists that could compromise safety, then no electrical supply shall be connected to the circuit until the fault has been dealt with satisfactorily.

If the fault cannot be corrected immediately but it is necessary to continue operation, an adequate temporary solution shall be used. This shall be reported to the owner of the equipment so that all parties are advised. Initial safety checks shall include:

- That capacitors are discharged: this shall be done in a safe manner to avoid the possibility of sparking;
- That no live electrical components and wiring are exposed while charging, recovering or purging the system;
- That there is continuity of earthing.

## **WARNING**

Sealed electrical components shall be replaced.

Intrinsically safe components must be replaced.

Check that cabling will not be subject to wear, corrosion, excessive pressure, vibration, sharp edges or any other adverse environmental effects. The check shall also take into account the effects of aging or continual vibration from sources such as compressors or fans.

Under no circumstances shall potential sources of ignition be used while searching for or detection of refrigerant leaks. A halide torch (or any other detector using a naked flame) shall not be used.

Electronic leak detectors may be used to detect refrigerant leaks but, in the case of flammable refrigerants, the sensitivity may not be adequate, or may need re-calibration. (Detection equipment shall be calibrated in a refrigerant-free area.) Ensure that the detector is not a potential source of ignition and is suitable for the refrigerant used. Leak detection equipment shall be set at a percentage of the LFL of the refrigerant and shall be calibrated for the refrigerant employed, and the appropriate percentage of gas (25 % maximum) is confirmed.

If a leak is suspected, all naked flames shall be removed/extinguished.

If a leakage of refrigerant which requires brazing is found, all of the refrigerant shall be recovered from the system, or isolated (by means of shut off valves) in a part of the system remote from the leak.

Leak detection fluids are also suitable for use with most refrigerants but the use of detergents containing chlorine shall be avoided as the chlorine may react with the refrigerant and corrode the copper pipe-work.

NOTE: Examples of leak detection fluids are

- bubble method,
- fluorescent method agents.

When breaking into the refrigerant circuit to make repairs - or for any other purpose - conventional procedures shall be used. However, for flammable refrigerants it is important that best practice be followed, since flammability is a consideration. The following procedure shall be adhered to:

- safely remove refrigerant following local and national regulations.
- evacuate.
- purge the circuit with inert gas .
- evacuate.
- continuously flush or purge with inert gas when using flame to open circuit, and.
- open the circuit.

The refrigerant charge shall be recovered into the correct recovery cylinders if venting is not allowed by local and national codes. For appliances containing flammable refrigerants, the system shall be purged with oxygen-free nitrogen to render the appliance safe for flammable refrigerants. This process might need to be repeated several times. Compressed air or oxygen shall not be used for purging refrigerant systems.

For appliances containing flammable refrigerants, refrigerants purging shall be achieved by breaking the vacuum in the system with oxygen-free nitrogen and continuing to fill until the working pressure is achieved, then venting to atmosphere, and finally pulling down to a vacuum. This process shall be repeated until no refrigerant is within the system. When the final oxygen-free nitrogen charge is used, the system shall be vented down to atmospheric pressure to enable work to take place.

The outlet for the vacuum pump shall not be close to any potential ignition sources, and ventilation shall be available.

Ensure that contamination of different refrigerants does not occur when using charging equipment. Hoses or lines shall be as short as possible to minimise the amount of refrigerant they contain.

Cylinders shall be kept upright. Ensure that the refrigeration system is grounded prior to charging the system with refrigerant.

Label the system when charging is complete (if it is not already labeled).

Take extreme care not to overfill the refrigeration system.

Prior to recharging the system, it shall be pressure-tested with the appropriate purging gas. The system shall be leak-tested on completion of charging but prior to commissioning. A follow up leak test shall be carried out prior to leaving the site.

Before carrying out this procedure, it is essential that the technician is completely familiar with the equipment and all its detail. It is recommended that all refrigerants are recovered safely. Prior to the task being carried out, an oil and refrigerant sample shall be taken in case analysis is required prior to re-use of reclaimed refrigerant. It is essential that electrical power is available before the task is commenced.

- a) Become familiar with the equipment and its operation.
- b) Isolate system electrically.
- c) Before attempting the procedure ensure that:
  - mechanical handling equipment is available, if required, for handling refrigerant cylinders;
  - all personal protective equipment is available and being used correctly;
  - the recovery process is supervised at all times by a competent person;
  - recovery equipment and cylinders conform to the appropriate standards.
- d) Pump down refrigerant system, if possible.
- e) If a vacuum is not possible, make a manifold so that refrigerant can be removed from various parts of the system.
- f) Make sure that the cylinder is situated on the scales before recovery takes place.
- g) Start the recovery machine and operate it in accordance with the manufacturer's instructions.
- h) Do not overfill cylinders. (No more than 80% volume liquid charge).
- i) Do not exceed the maximum working pressure of the cylinder, even temporarily.
- j) When the cylinders have been filled correctly and the process has been completed, make sure that the cylinders and the equipment are removed from site promptly and all isolation valves on the equipment are closed off.
- k) Recovered refrigerant shall not be charged into another refrigeration system unless it has been cleaned and checked.

Equipment shall be labeled stating that it has been de-commissioned and emptied of refrigerant. The label shall be dated and signed. Ensure that there are labels on the equipment stating the equipment contains flammable refrigerant.

When removing refrigerant from a system, either for servicing or decommissioning, it is recommended that all refrigerants are removed safely.

When transferring refrigerant into cylinders, ensure that only appropriate refrigerant recovery cylinders are employed. Ensure that the correct number of cylinders for holding the total system charge is available. All cylinders to be used are designated for the recovered refrigerant and labelled for that refrigerant (i.e. special cylinders for the recovery of refrigerant). Cylinders shall be complete with pressure-relief valve and associated shut-off valves in good working order. Empty recovery cylinders are evacuated and, if possible, cooled before recovery occurs.

The recovery equipment shall be in good working order with a set of instructions concerning the equipment that is at hand and shall be suitable for the recovery of the flammable refrigerant. If in doubt, the manufacturer should be consulted. In addition, a set of calibrated weighing scales shall be available and in good working order. Hoses shall be complete with leak-free disconnect couplings and in good condition.

The recovered refrigerant shall be processed according to local legislation in the correct recovery cylinder, and the relevant waste transfer note arranged. Do not mix refrigerants in recovery units and especially not in cylinders.

If compressors or compressor oils are to be removed, ensure that they have been evacuated to an acceptable level to make certain that flammable refrigerant does not remain within the lubricant. The compressor body shall not be heated by an open flame or other ignition sources to accelerate this process. When oil is drained from a system, it shall be carried out safely.

Do not use the air conditioner for other purposes. In order to avoid any quality deterioration, do not use the unit for the cooling of precision instruments, food, plants, animals or works of art. Before cleaning, be sure to stop the operation, turn the breaker off or unplug the supply cord. Otherwise, electric shock and injury may occur.

In order to avoid electric shock or fire, make sure that an earth leak detector is installed.

Never touch the air outlet or the horizontal blades while the swing flap is in operation. Your fingers may be caught or the unit may break down.

Never put any objects into the air inlet or outlet.

Objects touching the fan at high speed can be dangerous.

Never inspect or service the unit by yourself.

Ask a qualified service person to perform this task.

Do not dispose of this product as unsorted municipal waste. This waste should be collected separately for special treatment. Do not dispose of electrical appliances as unsorted municipal waste. Use separate collection facilities. Contact your local government for information regarding the connection systems available.

If electrical appliances are disposed of in landfills or dumps, hazardous substances can leak into the groundwater and get into the food chain, harming your health and well-being.

To prevent refrigerant leak, contact your dealer.

When the system is installed and operates in a small room, it is required to maintain the concentration of the refrigerant below the limit, in case a leak occurs. Otherwise, oxygen in the room may be affected, resulting in a serious accident.

The refrigerant in the air conditioner is safe and normally does not leak.

If the refrigerant leaks into the room and comes into contact with the fire of a burner, a heater or a cooker, a harmful gas could be released.

Turn off any combustible heating devices, ventilate the room, and contact the dealer where you purchased the unit.

Do not use the air conditioner until a service person confirms that the refrigerant leak is repaired.

Keep ventilation openings clear of obstruction.

### CAUTION

Be sure the air conditioner is earthed.

In order to avoid electric shock, make sure that the unit is earthed and that the earth wire is not connected to a gas or water pipe, lightning conductor or telephone earth wire.

Do not operate the air conditioner with a wet hands. An electric shock may happen.

Do not touch the heat exchanger fins. These fins are sharp and could cut you.

To avoid oxygen deficiency, ventilate the room sufficiently if equipment with a burner is used together with the air conditioner.

Arrange the drain hose to ensure smooth drainage. Incomplete drainage may cause wetting of the building, furniture, etc.

Never touch the internal parts of the controller.

Do not remove the blower access panel. Some parts inside are dangerous to touch, and machine troubles may occur.

Attention is drawn to the fact that additional transportation regulations may exist with respect to equipment containing flammable gas. The maximum number of pieces of equipment or the configuration of the equipment permitted to be transported together will be determined by the applicable transport regulations.

Signs for similar appliances used in a work area are generally addressed by local regulations and give the minimum requirements for the provision of safety and/or health signs for a work location.

All required signs are to be maintained and employers should ensure that employees receive suitable and sufficient instruction and

training on the meaning of appropriate safety signs and the actions that need to be taken in connection with these signs.

The effectiveness of signs should not be diminished by too many signs being placed together.

Any pictograms used should be as simple as possible and contain only essential details.

The storage of the appliance should be in accordance with the applicable regulations or instructions, whichever is more stringent.

Storage package protection should be constructed such a way that mechanical damage to the equipment inside the package will not cause a leak of the REFRIGERANT CHARGE.

The maximum number of pieces of equipment permitted to be stored together will be determined by local regulations.

Do not operate the air conditioner when using a room fumigation - type insecticide. Failure to observe this precaution could cause the chemicals to become deposited in the unit, which could endanger the health of those who are hypersensitive to chemicals. It may also cause the refrigerant sensor to alarm.

Do not place appliances which produce open flame in places exposed to the air flow from the unit or under the indoor unit. It may cause incomplete combustion or deformation of the unit due to the heat.

Do not install the air conditioner in a location where flammable gas may leak out. If the gas leaks out and stays around the air conditioner, a fire may break out.

The appliance uses R454B refrigerant.



## 2 INTRODUCTION

MPCP\*N10\* and MPCE\*N10\* Fan Coils are designed for horizontal orientation and are suitable for ceiling installations in conditioned spaces. These units are available with field -installed electric heat, and are used indoors as the fan coil for split -system heat pumps or air conditioners. MPCP\*N10\* and MPCE\*N10\* models all have a factory-installed TXV and are available in 18,000 through 36,000 Btuh nominal cooling capacities. MPCP\*N10\* units utilize a 3-speed PSC motor, and MPCE\*N10\* units utilize a 5-speed EMC motor.

Field -installed heaters are available in 3,5,6,7.5, and 10 kW sizes. The coil is equipped with sweat-type connections and is vapor-charged with dry nitrogen.

Units are designed for horizontal applications only. Local codes may limit this free-air-return type unit to installation in single-level applications.

### ⚠ WARNING

#### ELECTRICAL OPERATION HAZARD

Failure to follow this warning could result in personal injury or death.

Before installing or servicing unit, always turn off all power to unit. There may be more than 1 disconnect switch. Turn off accessory heater power if applicable. Lock out and tag switch with a suitable warning label.

### ⚠ WARNING



#### EXPLOSION HAZARD

Failure to follow this warning could result in death, serious personal injury, and/or property damage.

Never use air or gases containing oxygen for leak testing or operating refrigerant compressors.

Pressurized mixtures of air or gases containing oxygen can lead to an explosion.

### ⚠ CAUTION

#### CUT HAZARD

Failure to follow this caution may result in personal injury.

Sheet metal parts may have sharp edges or burrs.

Use care and wear appropriate protective clothing and gloves when handling parts.

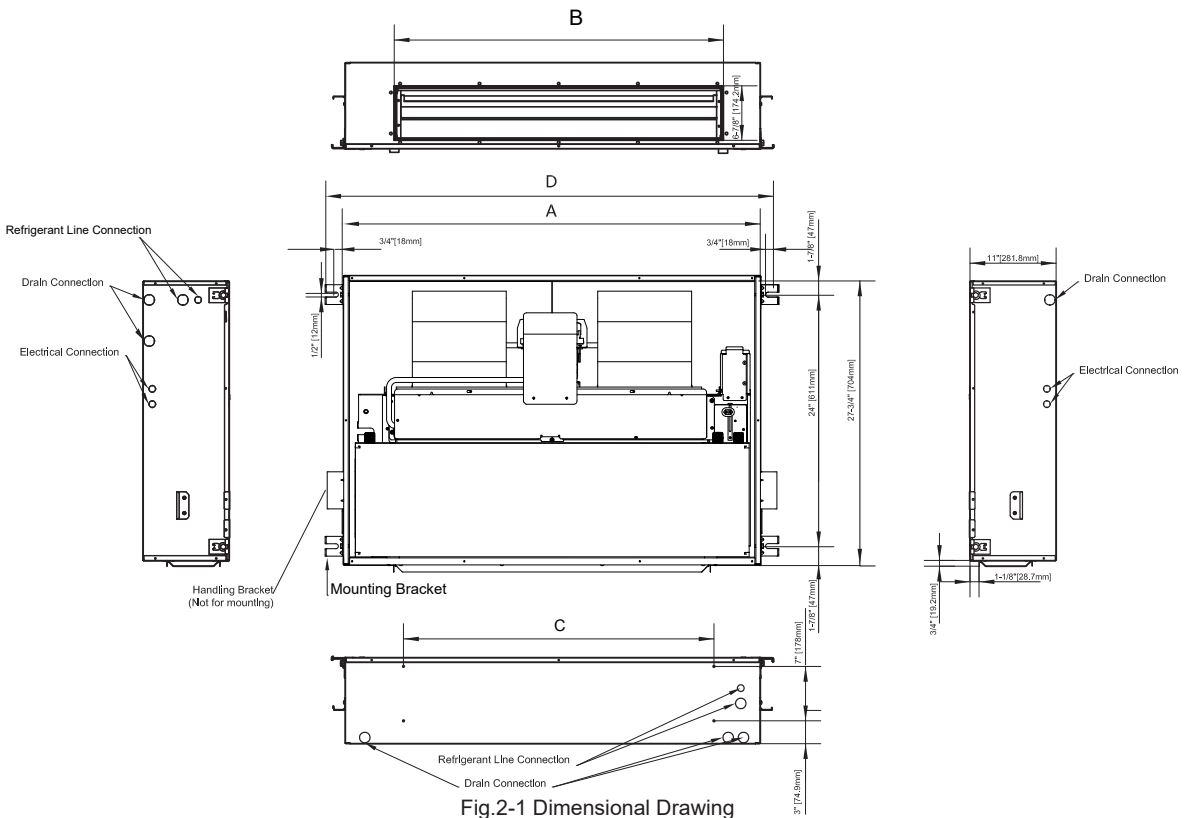

Model Size	Dimensions- inches [mm]				Unit Operating Weight Lbs. (kg)
	A	B	C	D	
18	39-3/4 [1010]	30-3/8 [771]	28 [711]	43-3/8 [1101]	116 (52.5)
24	39-3/4 [1010]	30-3/8 [771]	28 [711]	43-3/8 [1101]	116 (52.5)
30	51-3/4 [1315]	42-3/8 [1076]	40 [1016]	55-3/8 [1406]	142 (64.5)
36	51-3/4 [1315]	42-3/8 [1076]	40 [1016]	55-3/8 [1406]	142 (64.5)

Table 2-1 Dimensional Data

## 3 INSTALLATION

### WARNING

These instructions are exclusively intended for qualified contractors and authorized installers.

Work on the refrigerant circuit with flammable refrigerant in safety group A2L may only be carried out by authorized heating contractors. These heating contractors must be trained in accordance with UL 60335-2-40, Section HH. The certificate of competence from an industry accredited body is required.

Work on electrical equipment may only be carried out by a qualified electrician.

Before initial commissioning, all safety – related points must be checked by the particular certified heating contractors. The system must be commissioned by the system installer or a qualified person authorized by the installer.

For installation of the indoor unit, refer to the corresponding installation and operation manual. If an indoor unit is installed in an unventilated area, the area shall be so constructed that should any refrigerant leak, it will not stagnate so as to create a fire or explosion hazard.

The appliance shall be stored so as to prevent mechanical damage from occurring.

Do not stack combustible materials on the surface of the indoor unit.

### 3.1 Refrigerant Charge and Room Area Limitations

In UL/CSA 60335-2-40, R454B refrigerant is classified as class A2L, which is mildly flammable. Therefore, R454B refrigerant is suitable for systems needing additional refrigerant charge and which will limit the area of the rooms being served by the system.

Similarly, the total amount of refrigerant in the system shall be less than or equal to the allowable maximum refrigerant charge. The allowable maximum refrigerant charge depends on the area of the rooms being served by the system.

### NOTE

The nouns in this section are explained as follows:

Mc: The actual refrigerant charge in the system.

A: the actual room area where the appliance is installed.

Amin: The required minimum room area.

Mmax: The allowable maximum refrigerant charge in a room.

Qmin : The minimum circulation airflow.

Anvmin: The minimum opening area for connected rooms.

TAmin: The total area of the conditioned space (For appliances serving one or more rooms with an air duct system).

TA: The total area of the conditioned space connected by air ducts.

### 3.1.1 The room area calculation requirements

### NOTICE

The space considered shall be any space which contains refrigerant-containing parts or into which refrigerant could be released.

The room area (A) of the smallest, enclosed, occupied space shall be used in the determination of the refrigerant quantity limits.

For determination of room area (A) when used to calculate the refrigerant charge limit, the following shall apply.

The room area (A) shall be defined as the room area enclosed by the projection to the base of the walls, partitions and doors of the space in which the appliance is installed.

Spaces connected by only drop ceilings, ductwork, or similar connections shall not be considered a single space.

Units mounted higher than 70-55/64 inches and spaces divided by partition walls that are no higher than 62-63/64 inches shall be considered a single space.

Rooms on the same floor and connected by an open passageway between the spaces can be considered a single room when determining compliance to Amin, if the passageway complies with all of the following.

- 1) It is a permanent opening.
- 2) It extends to the floor.
- 3) It is intended for people to walk through.

The area of the connected rooms, on the same floor, connected by permanent opening in the walls and/or doors between occupied spaces, including gaps between the wall and the floor, can be considered a single room when determining compliance to Amin, provided all of the following conditions are met as Figure 3-1.

#### 1) Low level opening

① The opening shall not be less than Anvmin in Table 3-1.

② The area of any openings above 11-13/16 inches from the floor shall not be considered in determining compliance with Anvmin.

③ At least 50% of the opening area of Anvmin shall be below 7-7/8 inches from the floor.

④ The bottom of the opening is not more than 3-15/16 inches from the floor.

⑤ The opening is a permanent opening that cannot be closed.

⑥ For openings extending to the floor the height shall not be less than 25/32 inches above the surface of the floor covering.

#### 2) High level opening

① The opening shall not be less than 50% of Anvmin in Table 3-1.

② The opening is a permanent opening that cannot be closed.

③ The opening shall be at least 59 inches above the floor.

④ The height of the opening is not less than 25/32 inches.

3) Room size requirement

- ① The room into which refrigerant can leak, plus the connected adjacent room(s) shall have a total area not less than  $A_{min}$ .  $A_{min}$  is shown in Table 3-3.
- ② The room area in which the unit is installed shall be not less than 20%  $A_{min}$ .  $A_{min}$  is shown in Table 3-3.

**NOTICE**

The requirement for the second opening can be met by drop ceilings, ventilation ducts, or similar arrangements that provide an airflow path between the connected rooms.

The minimum opening for natural ventilation ( $A_{nmin}$ ) in connected rooms is related to the room area ( $A$ ), the actual refrigerant charge of refrigerant in the system ( $M_c$ ), and the allowable MAXIMUM REFRIGERANT CHARGE in the system ( $M_{max}$ ),  $A_{nmin}$  can be determined according to Table 3-1.

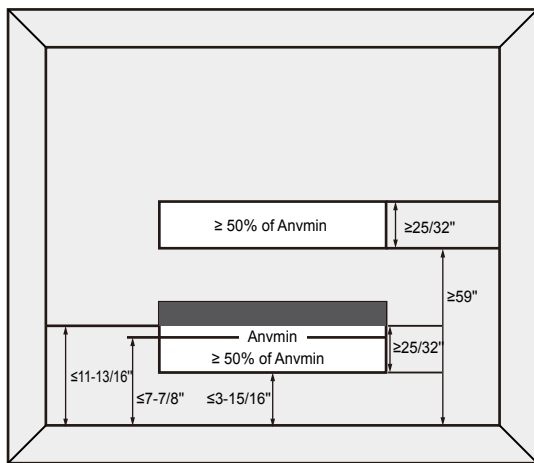

Fig.3-1 Opening Conditions for Connected Rooms

The minimum opening area for connected rooms

$A$ (ft <sup>2</sup> )	$M_c$ (□lbs□oz)		$M_{max}$ (□lbs□oz)		$A_{nmin}$ (ft <sup>2</sup> )
	lbs	oz	lbs	oz	
100	17	3	6	10	1.3
110	17	3	7	5	1.2
120	17	3	8	0	1.1
130	17	3	8	10	1.0
140	17	3	9	5	1.0
150	17	3	10	0	0.9
160	17	3	10	10	0.8
170	17	3	11	5	0.7
180	17	3	12	0	0.6
190	17	3	12	10	0.5
200	17	3	13	5	0.5
210	17	3	14	0	0.4
220	17	3	14	10	0.3
230	17	3	15	5	0.2
240	17	3	16	0	0.1
250	17	3	16	10	0.1
260	17	3	17	5	0.0

Table 3-1

Note: Take the  $M_c=17$  lbs 3 oz as an example.

For appliances serving one or more rooms with an air duct system, The room area calculation shall be determined based on the total area of the conditioned space (TA) connected by ducts taking into consideration that the circulating airflow distributed to all the rooms by the appliance integral indoor fan will mix and dilute the leaking refrigerant before entering any room.

**3.1.2. The allowed maximum refrigerant charge and required minimum room area**

If the fan incorporated to an appliance is continuously operated or operation is initiated by a REFRIGERANT DETECTION SYSTEM with a sufficient CIRCULATION AIRFLOW rate, the allowable maximum refrigerant charge ( $M_{max}$ ) and the required minimum room area ( $A_{min}/T_{Amin}$ ) is shown in Table 3-2 and Table 3-3.

The allowable maximum refrigerant charge

$A/T_A$ (ft <sup>2</sup> )	$M_{max}$ (□lbs□oz)		$A/T_A$ (ft <sup>2</sup> )	$M_{max}$ (□lbs□oz)	
	lbs	oz		lbs	oz
40	2	10	160	10	10
50	3	5	170	11	5
60	4	0	180	12	0
70	4	10	190	12	10
80	5	5	200	13	5
90	6	0	210	14	0
100	6	10	220	14	10
110	7	5	230	15	5
120	8	0	240	16	0
130	8	10	250	16	10
140	9	5	260	17	5
150	10	0			

Table 3-2

The required minimum room area

$M_c$ (□lbs□oz)		$A_{min}/T_{Amin}$ (ft <sup>2</sup> )	$M_c$ (□lbs□oz)		$A_{min}/T_{Amin}$ (ft <sup>2</sup> )
lbs	oz		lbs	oz	
4	6	66.1	11	0	165.3
4	13	72.7	11	7	171.9
5	4	79.3	11	14	178.5
5	11	86.0	12	5	185.1
6	2	92.6	12	12	191.7
6	9	99.2	13	3	198.4
7	0	105.8	13	10	205.0
7	7	112.4	14	1	211.6
7	15	119.0	14	8	218.2
8	6	125.6	14	15	224.8
8	13	132.2	15	6	231.4
9	4	138.8	15	14	238.0
9	11	145.5	16	5	244.6
10	2	152.1	16	12	251.2
10	9	158.7	17	3	257.9

Table 3-3

The minimum circulation airflow

Mc		Amin/Tamin		Mc		Amin/Tamin	
lb-oz	kg	CFM	m³/h	lb-oz	kg	CFM	m³/h
4-6	2.0	119	202.3	11-0	5.0	298	506.6
4-13	2.2	131	222.7	11-7	5.2	310	527.0
5-4	2.4	143	243.1	11-14	5.4	322	574.4
5-11	2.6	155	263.5	12-5	5.6	334	567.8
6-2	2.8	167	283.9	12-12	5.8	346	588.2
6-9	3.0	179	304.3	13-3	6.0	358	608.6
7-0	3.2	191	324.7	13-10	6.2	370	629.0
7-7	3.4	203	345.1	14-1	6.4	382	649.4
7-15	3.6	215	365.5	14-8	6.6	394	669.8
8-6	3.8	227	385.9	14-15	6.8	406	690.2
8-13	4.0	239	406.3	15-6	7.0	418	710.6
9-4	4.2	251	426.7	15-14	7.2	430	731.0
9-11	4.4	263	447.1	16-5	7.4	442	751.4
10-2	4.6	275	467.5	16-12	7.6	454	771.8
10-9	4.8	287	487.9	17-3	7.8	466	792.2

Table 3-4

**NOTE**

The allowable maximum refrigerant charge of the Table 3-2 or the required minimum room area of the Table 3-3 is available only if the following conditions are met:

Minimum velocity of 3.28ft/s, which is calculated as the indoor unit airflow divided by the nominal face area of the outlet. And the grill area shall not be deducted.

Minimum airflow rate must meet the corresponding values in Table 3-4, which is related to the actual refrigerant charge of the system (Mc).

R454B refrigerant leakage sensor is configured.

**NOTE**

The maximum refrigerant limit described above applies to unventilated areas. If adding additional measures, such as areas with mechanical ventilation or natural ventilation, The maximum refrigerant charge can be increased or the minimum room area can be reduced.

R454B refrigerant leakage sensor is configured for the indoor unit, meets the incorporated circulation airflow requirements, the maximum refrigerant charge or minimum room area can be determined according to Table 3-2 or Table 3-3.

**NOTICE**

If the actual room area, air outlet height, and refrigerant charge amount are not reflected in the above table, more severe cases need to be considered according to the data in the Table 3-1, 3-2, 3-3, 3-4.

● Installation scheme flow chart

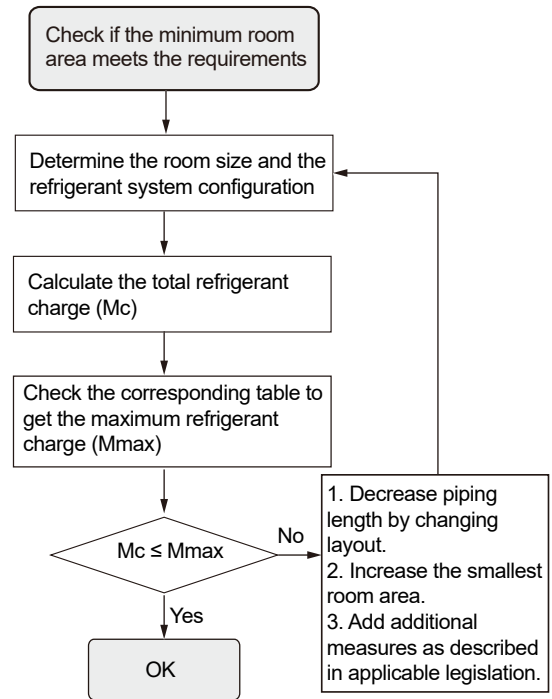

Fig.3-2

## 3.2 Refrigerant Line

The suction pipe and liquid pipe of the indoor unit need to be protected and cannot be grabbed when moving the indoor unit.

Keep the coil connections sealed until refrigerant connections are made. See the Installation Instructions for the outdoor unit for details on line sizing, tubing installation, and charging information.

Coil is shipped with Nitrogen. Evacuate the system before charging with refrigerant.

Install refrigerant tubing so that it does not block service access to the front of the unit.

Nitrogen should flow through the refrigerant lines while brazing.

Use a brazing shield to protect the cabinet's paint and a wet rag to protect the rubber grommet and input pipe's TXV seal ring from being damaged by torch flames.

After the refrigerant connections are made, seal the gap around the connections with pressure sensitive gasket.

The pipe-work including piping material, pipe routing, and installation shall include protection from physical damage in operation and service, and be in compliance with national and local codes and standards, such as ASHRAE 15, ASHRAE 15.2, IAPMO Uniform Mechanical Code, ICC International Mechanical Code. inspection prior to being covered or enclosed; or CSA B52. All field joints shall be accessible for inspection prior to being covered or enclosed.

All joints made in the installation between parts of the refrigerating system, with at least one part charged, shall be made in accordance with the following:

— A brazed, welded, or mechanical connection shall be made before opening the valves to permit refrigerant to flow between the refrigerating system parts. A vacuum valve shall be provided to evacuate the interconnecting pipe or any uncharged refrigerating system part.

— Mechanical connectors used indoors shall comply with ISO 14903. When mechanical connectors are reused indoors, sealing parts shall be renewed. When flared joints are reused indoors, the flare part shall be refabricated.

— Refrigerant tubing shall be protected or enclosed to avoid damage.

— Flexible refrigerant connectors (such as connecting lines between the indoor and outdoor unit) that may be displaced during normal operation shall be protected against mechanical damage.

Compliance is checked according to the installation instructions and a trial installation, if necessary.

Field-made refrigerant joints indoors shall be tightness tested. The test method shall have a sensitivity of 5 grams per year of refrigerant or better under a pressure of at least 0,25 times the maximum allowable pressure. No leak shall be detected.

After completion of field piping for split systems, the field pipework shall be pressure tested with an inert gas and then vacuum tested prior to refrigerant charging, according to the following requirements.

The minimum test pressure for the low side of the system shall be the low side design pressure and the minimum test pressure for the high side of the system shall be the high side design pressure, unless the high side of the system, cannot be isolated from the low side of the system in which case the entire system shall be pressure tested to the low side design pressure.

Field-made refrigerant joints indoors shall be tightness tested. The test method shall have a sensitivity of 5 grams per year of refrigerant or better under a pressure of at least 0,25 times the maximum allowable pressure. No leak shall be detected.

— mechanical joints in compliance with ISO 14903 or UL 207 (U.S. only).

— welded or brazed joints.

— joints in enclosures that vent to the unit or to the outside.

Compliance is checked by inspection and tests.

### NOTE

It is recommended to install a filter dryer, the filter drier should be installed in the liquid line between the outdoor unit's liquid line service valve and the indoor coil's metering device. The filter dryer should be compatible with R454B refrigerant.

## 3.3 Installation Instructions

### Step 1 — Check Equipment

Unpack unit and move to final location. Remove from carton, avoid lifting from blower wheels, taking care not to damage unit. Inspect equipment for damage prior to installation. File claim with shipping company if shipment is damaged or incomplete. Locate rating plate on unit. It contains information needed to properly install unit. Check rating plate to be sure unit matches job specifications.

#### NOTE

Installation clearance from combustible materials is 0" (0 mm) from unit and supply-air duct.

### Step 2 — Mount Fan Coil

#### For conversion to horizontal return:

1. Remove the back panel from the casing assembly.
2. Using the dimples on the back of the casing as a guide, pre-cut the insulation and remove to prevent damage that may occur while cutting the new return opening.
3. Cut the return opening into the sheet metal using the dimples as a guide.
4. Reinstall the back panel on to the casing.
5. Field fabricate and mount a cover panel to completely seal bottom return opening of the fan coil.

#### Fan coil Mounting

Mounting brackets are provided on all four corners of the casing for attachment of the fan coil to supporting structure. The supporting structure must be designed to safely support the full weight of the fan coil. Field supplied washers and bolts capable of supporting the fan coil load should be used to secure the fan coil to the supporting structure at the mounting brackets.

The fan coil must be mounted level to ensure proper drainage of condensate. If the supporting structure is not level at the points of fan coil attachment, then spacers must be used to level the fan coil.

After mounting unit, install refrigerant tubing as follows:

1. Route tubing to connection points.
2. Remove plugs from liquid and vapor lines.
3. Wrap the TXV with a wet rag to prevent overheating.
4. Shield casing insulation with sheet metal in the area you will be brazing.
5. Braze connections using either silver bearing or non-silver bearing brazing material. Do not use soft solder (materials which melt below 800 °F / 427°C). Consult local code requirements. Always flow nitrogen through the system refrigerant lines while brazing.
6. Pressurize system and leak-test. Repeat procedure until leak-free.
7. After the pipes are connected between the indoor unit and the outdoor unit, the hole of the metal shell that covering junctions of indoor pipes attached to the outdoor pipes shall be covered by material that meets 5VA flame retardant.

#### CAUTION

##### ENVIRONMENTAL HAZARD

Failure to follow this caution may result in environmental damage.

Do not vent refrigerant to atmosphere. Recover during system repair or final unit disposal.

### Step 3 — Supply- Air Connections

When fan coil is equipped with an electric heater, install air ducts in accordance with standards 90A and 90B of National Fire Protection Association (NFPA). Use of flexible connectors between ductwork and unit will prevent transmission of vibration. When electric heater is installed, use heat-resistant material for a flexible connector between ductwork and unit air discharge connection. Ductwork passing through unconditioned space must be insulated and covered with a vapor barrier.

**NOTE:** Local codes may limit this unit to single-level applications.

#### WARNING

##### INJURY HAZARD

Failure to follow this warning could result in personal injury or death.

Do not, under any circumstances, connect return ductwork to any other heat-producing device such as fireplace inserts, stoves, etc. Unauthorized use of such devices may result in fire, carbon monoxide poisoning, explosion, personal injury or property damage.

Design the duct system in accordance with "ACCA" Manual "0" Design for Residential Winter and Summer Conditioning and Equipment Selection. Latest editions are available from: "ACCA" Air Conditioning Contractors of America. If duct system incorporates flexible air duct, be sure pressure drop information (straight length plus all turns) shown in "ACCA" Manual "D" is accounted for in system.

#### Return Air

All return air must be filtered. Fan coil can be installed with a return-air duct or in a free return application. When installed as a ducted return, an insulated cover for the bottom casing opening must be field fabricated. When installed as free air return, the space housing the fan coil must be fully sealed except for the return air connection to the conditioned space. Air filters should be located at the return air openings to the fan coil location.

## ⚠️ WARNING

If appliances connected via an air duct system to one or more rooms are installed in a room with an area less than shown in section 3.1 Table 3-3, that room shall be without continuously operating open flames (e.g. an operating gas appliance) or other potential ignition sources (for e.g. an operating electric heater, hot surfaces). A flame-producing device may be installed in the same space if the device is provided with an effective flame arrest.

For appliances connected via an air duct system to one or more rooms, auxiliary devices which may be a potential ignition source shall not be installed in the duct work. Examples of such potential ignition sources are hot surfaces with a temperature exceeding 700°C and electric switching devices.

For appliances connected via an air duct system to one or more rooms, only auxiliary devices approved by the appliance manufacturer or declared suitable with the refrigerant shall be installed in connecting ductwork.

### Step 4 — Condensate Drain

Condensate pan has primary and secondary drain connections to meet FHA requirements. These connections have 3/4" (19 mm) male pipe threads. Tubing for all condensate drains should be a minimum of 7/8" (22 mm) OD. Drain lines from condensate pan to exterior of unit must be plastic pipe. Drain should be pitched downward at a slope of 1" per 10' (25 mm per 3 m).

Additional mounting holes are available if more slope is desired by installer. See Fig.3-3 for drain pan alternate mounting hole locations. If coil is located in or above a living space where damage may result from condensate overflow, a separate 3/4" (19 mm) drain must be provided from secondary drain connection. Run this drain to a place in compliance with local installation codes where it will be noticed when unit is operational.

Condensate flow from secondary drain indicates a plugged primary drain. Install a 2" (51 mm) trap in condensate drain line as close to coil as possible. A factory approved drain trap kit, KFAET0150ETK, is available. Make sure that the top of trap is below connection to drain pan. Prime all traps, test for leaks, and insulate in areas where sweating of the traps and drain lines could potentially cause water damage. Consult local codes for additional restrictions or precautions.

Accessory UV -C lights are not approved for use with this fan coil.

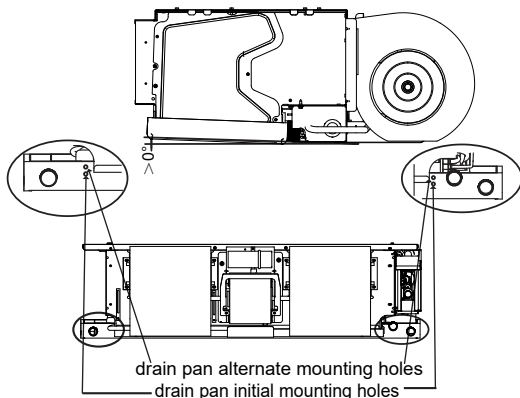

Fig. 3-3 Alternate condensate pan mounting holes

### Step 5 — Electrical Connections

## ⚠️ WARNING

### ELECTRICAL OPERATION HAZARD

Failure to follow this warning could result in personal injury or death.

Before installing or servicing unit, always turn off all power to unit. There may be more than one disconnect switch. Turn off accessory heater power if applicable. Lock out and tag switch with a suitable warning label.

Refer to unit wiring instructions for recommended wiring procedures. Use No.18 AWG color-coded, insulated (35°C minimum) wire to make low-voltage connections between thermostat and unit. If thermostat is located more than 100 ft. (30m) from unit as measured along low-voltage wire, use No.16 AWG color-coded, insulated (35°C minimum) wire.

**NOTE:** Before proceeding with electrical connections, make certain that voltage, frequency, and phase correspond to that specified on rating plate. Also, check to be sure that the service provided by utility is sufficient to handle additional load imposed by this equipment.

Refer to unit wiring label for proper field high - and low -voltage wiring. Make all electrical connections in accordance with NEC and any local codes or ordinances that might apply. Unit must have a separate branch electrical circuit.

## ⚠️ WARNING

### ELECTRICAL SHOCK HAZARD

Failure to follow this warning could result in personal injury or death.

Field wires on side of disconnect found in fan coil remain live, even when circuit breaker is off. Service and maintenance to incoming wiring cannot be performed until main disconnect switch (remote to the unit) is turned off. Lock out and tag switch with a suitable warning label.

Unit cabinet must have a continuous electrical path to ground in order to minimize potential for personal injury or death if an electrical fault should occur. This ground may consist of electrical wire or approved conduit when installed in accordance with existing codes. (See Step 3. above.)

**NOTE:** All units are shipped from factory wired for 240VAC transformer operation. For 208VAC operation, move primary lead from 240VAC terminal to 208VAC terminal.

See Figs 3-4 ,3-5 for field low-voltage wiring. See Fig 2-1 for location of the electrical inlets. For maximum ampacity and over-current protection, see unit rating plate or product data sheet.

1. Provide power supply for unit being installed in accordance with unit wiring diagram and rating plate.
2. Connect line-voltage leads to the harness pigtail or the heat-kit terminal block. Use copper wire only.
3. Use UL listed conduit and conduit connector for connecting line-voltage leads to unit and obtaining proper ground. If conduit connection uses reducing washers, a separate ground wire must be used. Grounding can also be accomplished by using the ground lug provided in the control box. Power wiring may be connected to either the right or left sides or top of unit. Knockouts of 7/8" (22 mm) dia. are provided for connection of power wiring to unit. Some heater sizes may require a conduit larger than the 7/8" opening; in this situation the high-voltage connection opening should be enlarged to fit the conduit. When removing the knockouts for electrical connections, an opening in the insulation should be cut to fit the opening. The cut edge of the insulation should be reinforced with foil tape to prevent fraying. The foil facing and insulation shall not be removed beyond the knockout opening size.
4. Install plastic grommet packed with unit in hole for low-voltage wires.
5. Connect low-voltage leads to thermostat and outdoor unit. See Fig. 3-4 and Fig. 3-5 as well as the outdoor unit wiring label.

### NOTE

For field installed electric heat, the leads from the 6-pin connector (L1 and L2) will need to be disconnected so the electric heat can plug into that connector. Refer to Fig. 3-9 and Fig. 3-10, and the electric heat installation instructions for more details.

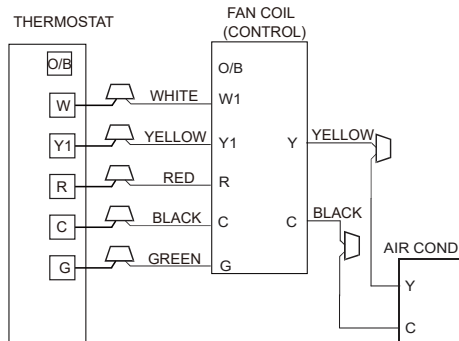

Fig. 3-4 Wiring Layout Air Conditioning Unit (Cooling and 1- Stage Heat)

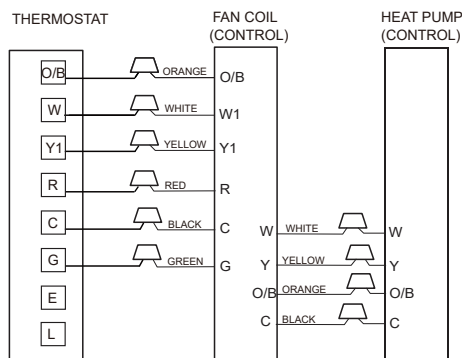

Fig. 3-5 Wiring Layout Heat Pump Unit (Cooling and 2- Stage Heat)

## Step 6 — Select Proper Blower Speed

Before operating unit, be sure that the proper blower speed has been selected. Fan speeds are selected manually using DIP switches on the control board. For both the MP(U/C)E\*N10\* and MP(U/C)P\*N10\* only the first 2 dip switches are used.

The dip switches on the MP(U/C)E\*N10\* units are located in the lower left portion of the control board. (SW6)

- MP(U/C)E18A1MN10TA, dip switch 1 is set to OFF, switch 2 is set to OFF.
- MP(U/C)E24A1MN10TA, dip switch 1 is set to OFF, switch 2 is set to ON.
- MP(U/C)E30B1MN10TA, dip switch 1 is set to ON, switch 2 is set to OFF.
- MP(U/C)E36B1MN10TA, dip switch 1 is set to ON, switch 2 is set to ON.

The dip switches on the MP(U/C)P\*N10\* units are located in the lower left portion of the control board. (SW6)

- MP(U/C)P18A1MN10TA, dip switch 1 is set to ON, switch 2 is set to OFF.
- MP(U/C)P24A1MN10TA, dip switch 1 is set to ON, switch 2 is set to OFF.
- MP(U/C)P30B1MN10TA, dip switch 1 is set to ON, switch 2 is set to OFF.
- MP(U/C)P36B1MN10TA, dip switch 1 is set to ON, switch 2 is set to ON.

To change the fan speed on model MP(U/C)E\*N10\*, refer to Fig.3-9.

To change the fan speed on model MP(U/C)P\*N10\*, refer to Fig.3-10.

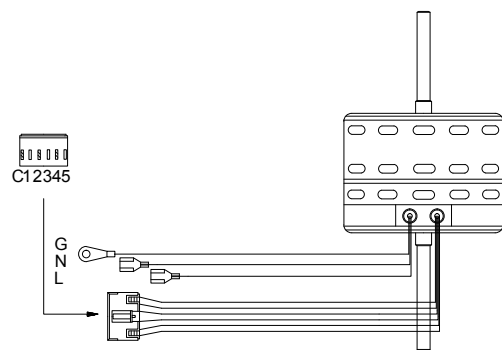

Fig.3-6 MPCE\*N10\* ECM Motor Speed Taps

Tap	Delay-off Times(s)	18	24	30	36
Tap 1	90	-	-	-	-
Tap 2	90	Default	-	-	-
Tap 3	90	-	Default	-	-
Tap 4	90	-	-	Default	-
Tap 5	90	-	-	-	Default

Table 3-5 MPCE\*N10\* ECM Motor Speed Taps

Tap	Delay-off Times(s)	18	24	30	36
Low	90	-	-	-	-
Middle	90	-	-	-	-
High	90	Default	Default	Default	Default

Table 3-6 MPCP\*N10\* PSC Motor Speed Taps

## Step 7 — TXV

### NOTE

The TXVs are preset at the factory and do not need adjustment for reliable operation.

### WARNING

These instructions are exclusively intended for qualified contractors and authorized installers.

Work on the refrigerant circuit with flammable refrigerant in safety group A2L may only be carried out by authorized heating contractors.

These heating contractors must be trained in accordance with UL 60335-2-40, Section HH. The certificate of competence from an industry accredited body is required.

Work on electrical equipment may only be carried out by a qualified electrician.

Before initial commissioning, all safety related points must be checked by the particular certified heating contractors. The system must be commissioned by the system installer or a qualified person authorized by the installer.

For installation of the indoor unit, refer to the corresponding installation and operation manual. If an indoor unit is installed in an unventilated area, the area shall be so constructed that should any refrigerant leak, it will not stagnate so as to create a fire or explosion hazard.

The appliance shall be stored so as to prevent mechanical damage from occurring.

Do not stack combustible materials on the surface of the indoor unit.

## Leak Dissipation System

### WARNING

#### PERSONAL INJURY OR PROPERTY DAMAGE HAZARD

Failure to follow proper R-454B mitigation system installation instructions can result in property damage, personal injury, or death.

If any fault codes are listed, please troubleshoot to prevent system malfunction.

Do not stack combustible materials on the surface of the indoor unit.

The units come equipped with a factory wired R-454B leak detection and dissipation system to ensure safe operation during a leak. The system consists of a bracket, a PCB, a A2L Detection Sensor, and a drain pan clip. Failure to install this system will result in potentially hazardous conditions and improper equipment operation, and void all system warranties and liabilities.

All units are shipped with the A2L Detection Sensor located on the input / output pipe side of the slope coil (Fig. 3-7).

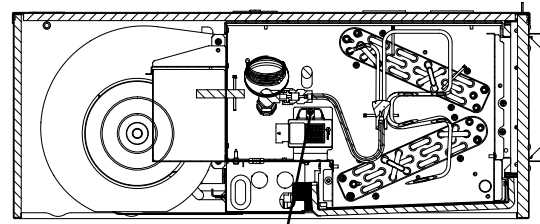

A2L Sensor

Fig. 3-7 Location of Dissipation Sensor

The A2L Detection Sensor is attached to a wiring harness that connects the sensor to the control board. Refer to Fig.3-4 and Fig.3-5 for low voltage field connections between the control board and the thermostat.

All control wires are labeled with the wire function and landing point.

### Leak Dissipation System Self-Test

Power on the unit and verify proper functioning of equipment. The green LED on the control board should be steady (Fig.3-7). If flash codes are present, see Table 3-7.

### CAUTION

The refrigerant leakage sensor can only use the factory model or the specified model indicated in the corresponding manual.

The R454B refrigerant leakage sensor must be used to activate the refrigerant shut-off device, the alarm device, incorporated circulation airflow or other emergency controls, which shall give an electrical signal at a predetermined alarm set point in response to leaked refrigerant.

The location of leakage sensors shall be chosen in relation to the different installation scenarios. Please refer to the indoor unit installation manual for specific requirements.

The installation of the refrigerant leakage sensor shall allow access for checking, repair or replacement by an authorized person.

The refrigerant leakage sensor shall be installed so its function can be verified easily.

The refrigerant leakage sensor shall be protected to prevent tampering or unauthorized resetting of the pre-set value.

To be effective, the refrigerant leakage sensor must be electrically powered at all times after installation, other than when servicing.

If the refrigerant leakage sensor detects a refrigerant leak, the fan will be turned on to the maximum, the compressor will stop running. you should immediately leave the leak area and notify a professional for handling.

The service life of the refrigerant sensor is 15 years, and it should be replaced after the service life.

## **⚠ WARNING**

LEAK DETECTION SYSTEM installed on indoor unit. Unit must be powered except for service. Continuous air circulation required for proper functioning. Unit must be powered except for service. This unit is equipped with electrically powered safety measures. To be effective, the unit must be electrically powered at all times after installation, other than when servicing.

## **NOTICE**

R454B refrigerant leakage sensor is configured for the indoor unit, the operation of fan can be initiated by R454B refrigerant sensor. meets the incorporated circulation airflow requirements. The allowed maximum refrigerant charge (Mmax) and the required minimum room area (Amin) can be determined according to Table 3-2 and Table 3-3.

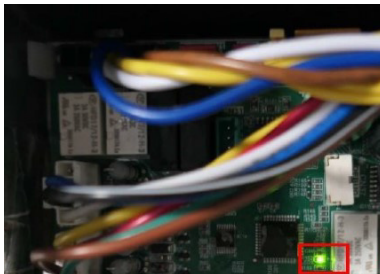
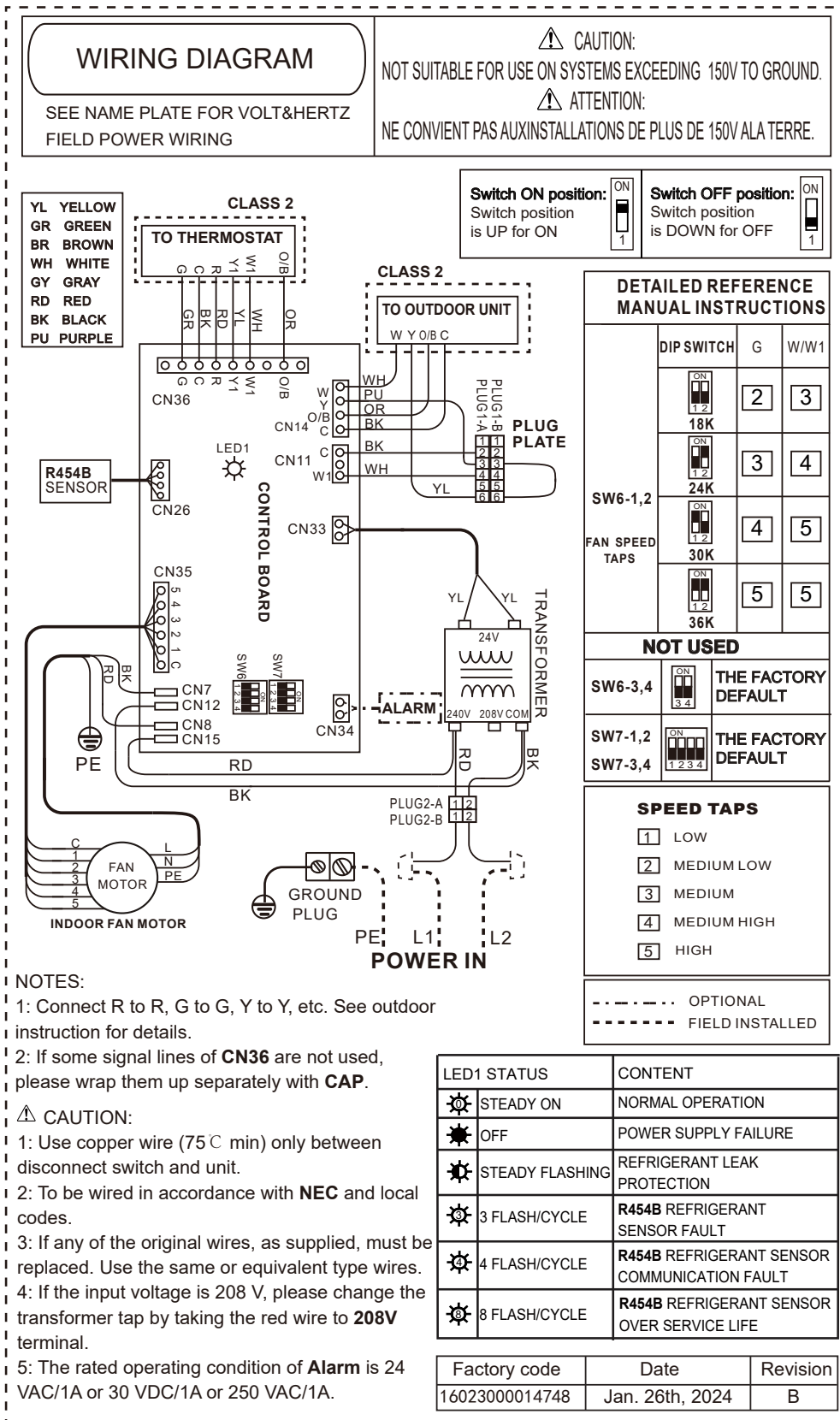

Fig. 3-8 Control Board LED

LED Status	Description
Steady ON	Normal Operation
OFF	Power Supply Failure
Keep Flashing	Refrigerant Leak Protection
3 Flash/Cycle	A2L Sensor Error
4 Flash/Cycle	A2L Sensor Communication Error
8 Flash/Cycle	A2L Sensor Over Service Life

Table 3-7 Control Board Test Functions

Ensure that the fan coil is able to meet the minimum required dissipation mode airflows. These required minimum airflow rates during Dissipation Mode are listed in Table 3-4. They are based on the total system refrigerant charge quantity.



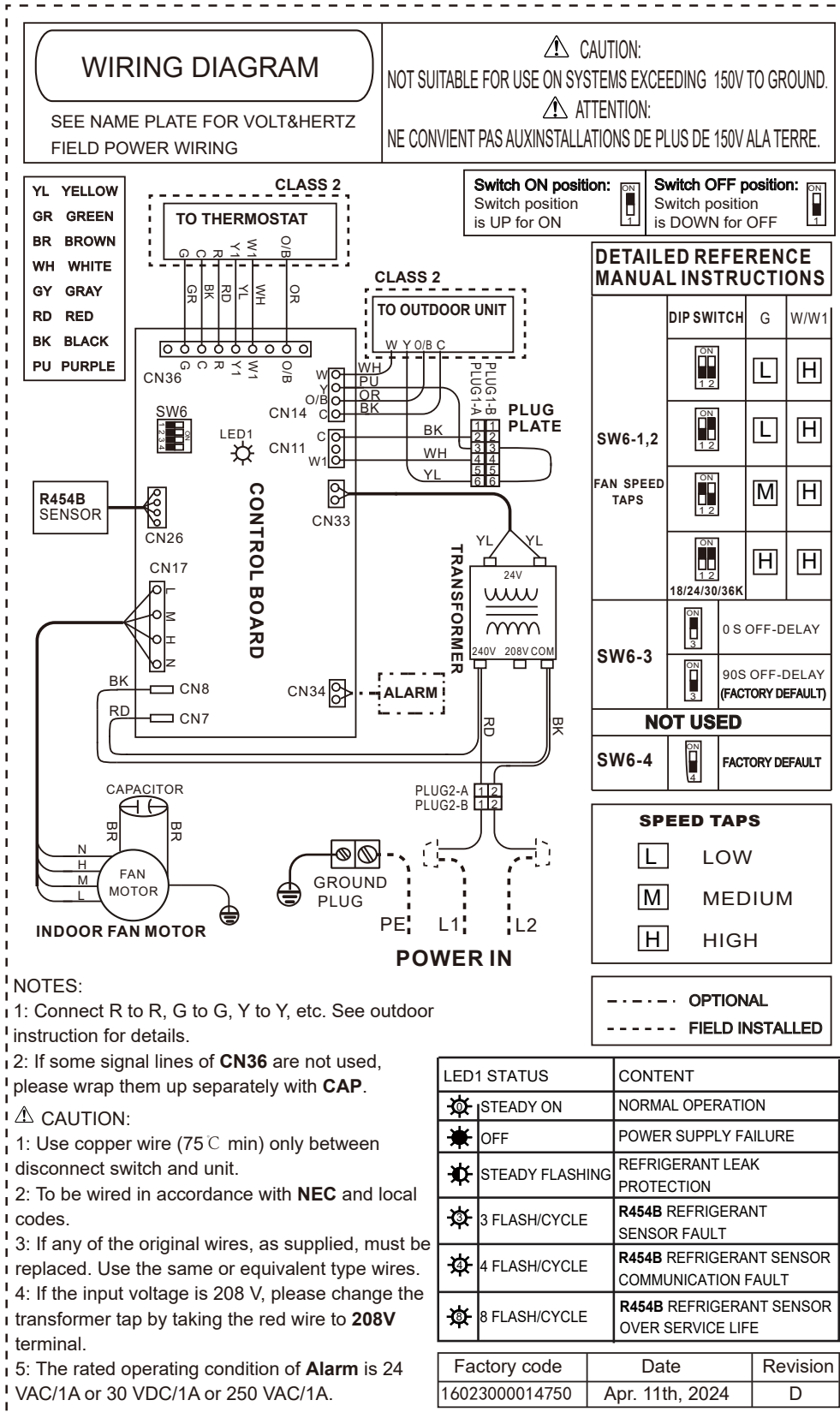

## 4 START-UP

Refer to outdoor unit Installation Instructions for system start-up instructions and refrigerant charging method details.

## 5 SEQUENCE OF OPERATION

**NOTE:** For units with ECM motor, the off-delay is programmed into the motor. Follow Table 3-5, ECM Motor Speed Taps & the corresponding blower off delays for each speed tap.

Follow Table 3-6, PSC Motor Speed Taps & the corresponding blower off delays for each speed tap.

### A. CONTINUOUS FAN

Thermostat closes R to G.G energizes and completes circuit to indoor blower motor. When G is de-energized, there is a 90s blower off-delay.

### B. COOLING MODE

Thermostat energizes R to G, and R to Y. G energizes and completes indoor blower motor. Y energizes outdoor unit. When cooling call is satisfied, G is de-energized, and there is a 90-second blower-off delay.

### C. HEAT PUMP HEATING MODE

Thermostat energizes R to G and R to Y and R to O/B (heat pump only).G energizes and completes circuit to indoor blower motor. Y energizes outdoor unit (O/B is energized for heat pump). When heating call is satisfied, G is de-energized, and there is a 90-second blower-off delay.

### D. HEAT PUMP HEATING WITH AUXILIARY ELECTRIC HEAT

Thermostat energizes R to G, R to Y, and R to W1 G energizes and completes circuit to indoor blower motor. W1 energizes electric heat relay(s) which completes circuit to heater element(s). When W1 is de-energized, electric heat relay(s) open, turning off heater elements. When G is de-energized there is a 90s blower off-delay.

**NOTE:** Due to blow through coil design, simultaneous heat pump and electric heat (auxiliary) operation will not occur. When W1 is energized, Y signal will be removed from outdoor.

### E. ELECTRIC HEAT OR EMERGENCY HEAT MODE

Thermostat closes R to W1. W1 energizes electric heat relay(s) which completes circuit to heater element(s). Blower motor is energized through normally closed contacts on fan relay. When W1 is de-energized, electric heat relay(s) opens, there is a 90s blower off-delay.

## 6 CARE AND MAINTENANCE

For continuing high performance and to minimize possible equipment failure, it is essential that periodic maintenance be performed on this equipment. The only required maintenance that may be performed by the consumer is filter maintenance.

### WARNING

#### ELECTRICAL OPERATION HAZARD

Failure to follow this warning could result in personal injury or death.

Disconnect all power to unit before servicing field wires or removing control package. The disconnect (when used) on access panel does not allow safe service to all other parts of unit.

If unit does not have a disconnect, disregard the foregoing.

Instead, make sure that a disconnecting means is within sight from, and is readily accessible from, the unit.

Disconnect all electrical power to unit before performing any maintenance or service on it. Lock out and tag switch with a suitable warning label.

The minimum maintenance requirements for this equipment are as follows:

1. Inspect and clean or replace air filter each month or as required.
2. Inspect cooling coil, drain pan, and condensate drain each cooling season for cleanliness. Clean as necessary.
3. Inspect blower motor and wheel for cleanliness each heating and cooling season. Clean as necessary.
4. Inspect electrical connections for tightness and controls for proper operation each heating and cooling season. Service as necessary.

### CAUTION

#### CUT HAZARD

Failure to follow this caution may result in personal injury.

Sheet metal parts may have sharp edges or burrs.

Use care and wear appropriate protective clothing and gloves when handling parts.

### NOTE

The installing technician should explain system operation to the consumer with particular emphasis on indoor fan coil operation sounds and filter maintenance.

## 7 AIRFLOW PERFORMANCE TABLES

Use for Selecting Heat Pump Speed of ECM Motor (Cased, Back Return)

Model	Motor Speed	CFM Wet Coil without Filter or Electric Heat, Cased, Back Return							
		External Static Pressure-Inches W.C.[kPa]							
		0[0]	0.1[.025]	0.15[.0375]	0.2[.050]	0.3[.075]	0.4[.100]	0.5[.125]	0.55[.1375]
18K	1	755	691	631	551	512	497	429	399
	2	876	821	766	710	658	639	594	574
	3	980	925	874	829	794	784	720	699
	4	1083	1034	988	947	912	904	860	703
	5	1191	1149	1105	1067	1019	998	869	737
24K	1	755	691	631	551	512	497	429	399
	2	876	821	766	710	658	639	594	574
	3	980	925	874	829	794	784	720	699
	4	1083	1034	988	947	912	904	860	703
	5	1191	1149	1105	1067	1019	998	869	737
30K	1	866	769	655	564	492	473	396	360
	2	1016	926	831	744	685	671	593	555
	3	1144	1067	986	898	840	826	757	719
	4	1272	1200	1128	1061	999	983	920	889
	5	1372	1306	1243	1181	1127	1113	1027	930
36K	1	866	769	655	564	492	473	396	360
	2	1016	926	831	744	685	671	593	555
	3	1144	1067	986	898	840	826	757	719
	4	1272	1200	1128	1061	999	983	920	889
	5	1372	1306	1243	1181	1127	1113	1027	930

Use for Selecting Heat Pump Speed of ECM Motor (Cased, Bottom Return)

Model	Motor Speed	CFM Wet Coil without Filter or Electric Heat, Cased, Bottom Return							
		External Static Pressure-Inches W.C.[kPa]							
		0[0]	0.1[.025]	0.2[.050]	0.3[.075]	0.38[.095]	0.4[.100]	0.5[.125]	0.55[.1375]
18K	1	770	704	638	560	505	493	431	406
	2	899	835	779	724	667	657	595	566
	3	1015	964	910	861	821	810	748	694
	4	1135	1085	1036	991	952	942	780	685
	5	1228	1183	1137	1057	971	943	773	687
24K	1	770	704	638	560	505	493	431	406
	2	899	835	779	724	667	657	595	566
	3	1015	964	910	861	821	810	748	694
	4	1135	1085	1036	991	952	942	780	685
	5	1228	1183	1137	1057	971	943	773	687
30K	1	904	775	678	586	516	498	416	379
	2	1052	950	834	755	693	677	595	563
	3	1186	1098	992	908	853	839	771	738
	4	1323	1245	1145	1063	1003	988	900	794
	5	1432	1361	1274	1183	1091	1068	903	799
36K	1	904	775	678	586	516	498	416	379
	2	1052	950	834	755	693	677	595	563
	3	1186	1098	992	908	853	839	771	738
	4	1323	1245	1145	1063	1003	988	900	794
	5	1432	1361	1274	1183	1091	1068	903	799

Table 7-1 Airflow Performance (CFM)

Use for Selecting Heat Pump Speed of PSC Motor (Cased, Back Return)

Model	Motor Speed	CFM Wet Coil without Filter or Electric Heat, Cased, Back Return							
		External Static Pressure-Inches W.C.[kPa]							
		0[0]	0.05[.0125]	0.1[.025]	0.15[.0375]	0.2[.050]	0.25[.0625]	0.3[.075]	0.35[.0875]
18	Low	698	674	646	620	582	527	457	361
	Medium	971	921	874	827	776	718	661	519
	High-Factory	1034	985	934	882	820	759	683	565
24	Low	698	674	646	620	582	527	457	361
	Medium	971	921	874	827	776	718	661	519
	High-Factory	1034	985	934	882	820	759	683	565
Model	Motor Speed	CFM Wet Coil without Filter or Electric Heat, Cased, Back Return							
		External Static Pressure-Inches W.C.[kPa]							
		0[0]	0.1[.025]	0.2[.050]	0.3[.075]	0.38[.095]	0.4[.100]	0.5[.125]	0.6[.150]
30	Low	1193	1094	1005	932	840	828	734	627
	Medium	1301	1209	1109	1033	972	929	840	726
	High-Factory	1419	1332	1219	1134	1070	1053	928	823
36	Low	1193	1094	1005	932	840	828	734	627
	Medium	1301	1209	1109	1033	972	929	840	726
	High-Factory	1419	1332	1219	1134	1070	1053	928	823

Use for Selecting Heat Pump Speed of PSC Motor (Cased, Bottom Return)

Model	Motor Speed	CFM Wet Coil without Filter or Electric Heat, Cased, Bottom Return							
		External Static Pressure-Inches W.C.[kPa]							
		0[0]	0.05[.0125]	0.1[.025]	0.15[.0375]	0.2[.050]	0.25[.0625]	0.3[.075]	0.35[.0875]
18	Low	736	706	673	634	579	526	430	363
	Medium	959	914	860	802	738	658	587	467
	High-Factory	997	956	907	846	775	700	614	512
24	Low	736	706	673	634	579	526	430	363
	Medium	959	914	860	802	738	658	587	467
	High-Factory	997	956	907	846	775	700	614	512
Model	Motor Speed	CFM Wet Coil without Filter or Electric Heat, Cased, Bottom Return							
		External Static Pressure-Inches W.C.[kPa]							
		0[0]	0.1[.025]	0.2[.050]	0.3[.075]	0.38[.095]	0.4[.100]	0.5[.125]	0.6[.150]
30	Low	1168	1092	1009	928	860	845	760	616
	Medium	1272	1199	1117	1039	969	953	870	764
	High-Factory	1396	1322	1251	1162	1083	1067	973	872
36	Low	1168	1092	1009	928	860	845	760	616
	Medium	1272	1199	1117	1039	969	953	870	764
	High-Factory	1396	1322	1251	1162	1083	1067	973	872

Table 7-1 Airflow Perform ance (CFM )

--- Shaded boxes represent airflow outside the required 300-450 cfm/ton.

**NOTES:**

1. Airflow data is without filter or electric heat accessory. Heater adds 0.05-in. static.
2. Use wet coil data for determining cooling airflow.
3. Accessory louver panel adds 0.05-in. Static.
4. When electric heater is working only, 300CFM for each ton is sufficient except 30K work with 10kW heat (≧900SCFM)

Size	CFM	
	Min	Max
18	450	675
24	600	900
30	750	1125
36	900	1350

Table 7-2 Required CFM Range for Heat Pump Operation

Model (Size, Ton)	Qv/(CFM)	Mc/kg
PSC 18	457	7.67

Table 7-3 Refrigerant Charge Limit

16123000004094 V.B